

Canon AUTO BELLOWS



Instructions

Table of Contents

Auto Bellows (brief explanation)	2	Tables (for FD lenses without a locking collar attached in standard direction)	20—23
Auto Bellows Composition and Accessories	3	Shooting with the Lens in Reverse	24—25
Main Features for the Auto Bellows	3	Table (in millimeters for FD lenses with a locking collar attached in reversed direction)	26
Nomenclature	4	Table (in millimeters for FD lenses without a locking collar attached in reversed direction)	27
Attachment to the Camera	5	Table (in inches for FD lenses with a locking collar attached in reversed direction)	28
Vertical/Horizontal Change of Camera Position	5	Table (in inches for FD lenses without a locking collar attached in reversed direction)	29
Lens Attachment	6	Exposure Factor Conversion Table	30
Bellows Adjustment	7	Flash Photography	31
Attachment of Canon Double Cable Release	8	Table of Accessory Length	32
Positioning the Camera on the Bellows	8	Introduction to System	
Focusing	8	Accessories for Close-ups and Photomacrography	33—35
Explanation of Bellows Scale	9		
Using the Bellows Scale	10		
Adjusting Canon Double Cable Release	11—12		
Simple Photographic Procedure	13		
Deciding Image Magnification	13		
Deciding Exposure	14		
Hints and General Precautions in Close-ups and Photomacrography	15		
Tables (for FD lenses with a locking collar attached in standard direction)	16—19		

Canon Auto Bellows

The Canon Auto Bellows is a high quality bellows for use with Canon single-lens reflex cameras which offers automatic diaphragm coupling when used with the Canon Double Cable Release. It is the cornerstone around which Canon's close-up system is built. With the use of a standard macro lens, magnifications from around 0.8X to 4X are possible. Many other applications are possible with the accessories in the system. The Canon Duplicator 35 for copying 35mm slides, Macrophoto Lenses for obtaining high magnifications, and photomicrography using a microscope, are only few examples of wide applications with the Auto Bellows.

Auto Bellows & Accessories

Auto Bellows Set (includes Canon Double Cable Release)

Size and Weight: 135mm (W) × 158mm (H) × 219mm (L), 1,170g

Related Accessories: Attachment Rings 52 and 55mm for lens reversal, Duplicator 35, Duplicator G, Macro Stage, Copy Stand 4, Copy Stand 5, Macrophoto Lens 35mm f/2.8, Macrophoto Lens 20mm f/3.5, Manual Diaphragm Adapter, Macrophoto Couplers FL, Macrophoto Adapters MA, Vari-Extension Tubes, Extension Tube M Set, etc.

Specifications subject to change without notice.

Main Features

1. Automatic Diaphragm Control with the Use of Double Cable Release

The lens standard of the Auto Bellows is equipped with a cable release socket. The automatic diaphragm of FD or FL lens is stopped down when the double cable release is pressed halfway and a picture is shot when it is pressed all the way. Metering and the confirmation of depth-of-field is, therefore, done when the double cable release is pressed halfway.

2. Three-way Focusing Systems

You can independently alter the lens-to-subject distance and camera-to-subject distance. As there is a supporting runner, it is also possible to move the whole bellows unit back and forth. To achieve a change in magnification and to make final adjustments in focusing, there is no need to move the whole set-up of bellows plus a tripod.

3. Reversing the Lens for Attachment

The lens standard can be reversed for reverse-mounting the lens. This means more than life-size magnification is possible without the use of the Macrophoto Coupler.

4. Revolving Mechanism

A vertical format shot is possible by rotation of the camera body 90°. With power winder accessory attached, the Auto Bellows permits camera body rotation at the rear of the rail.

5. The Bellows Extension of from 39mm to 175mm

6. Sturdily-built Construction for Durability.

Nomenclature

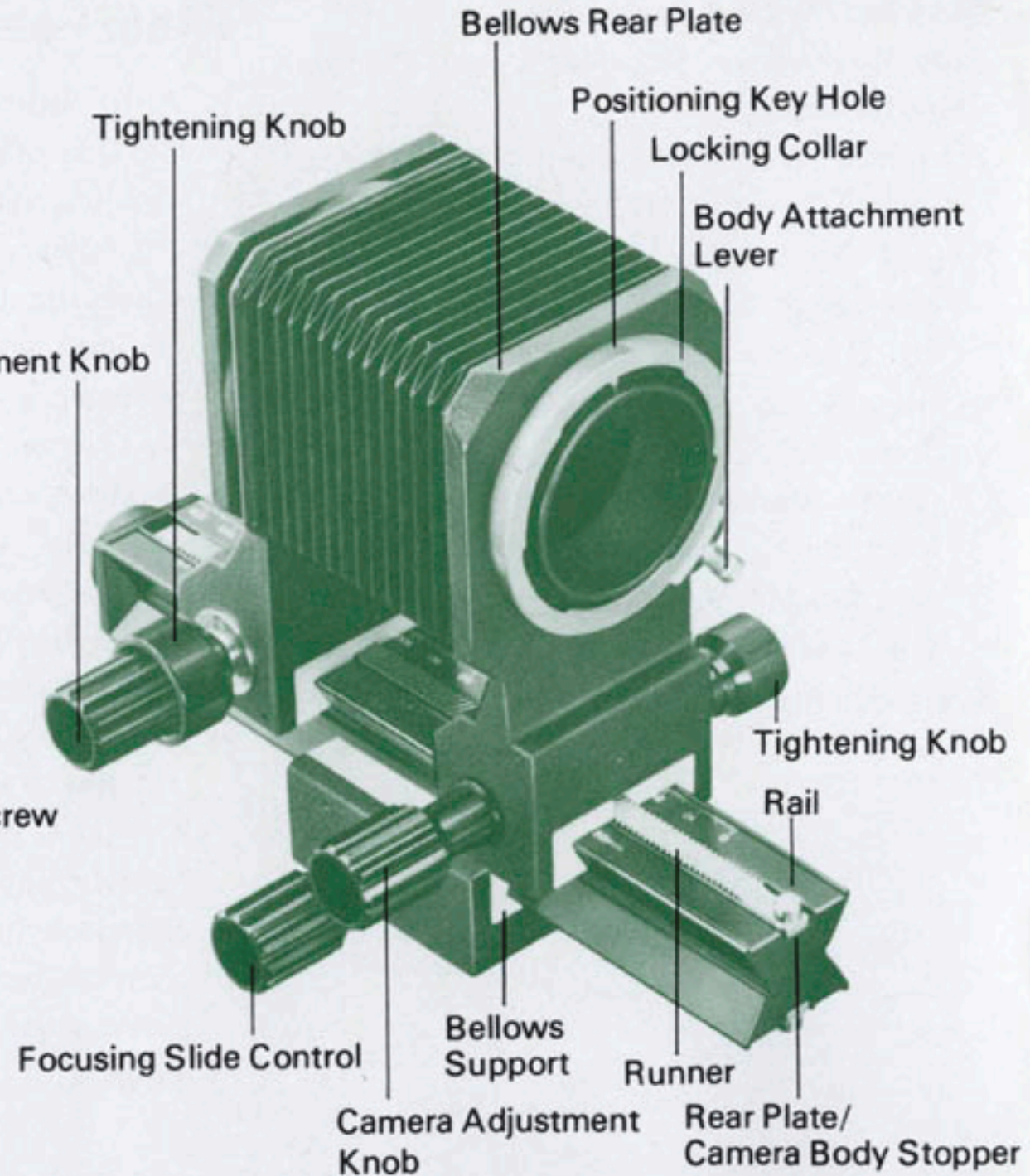
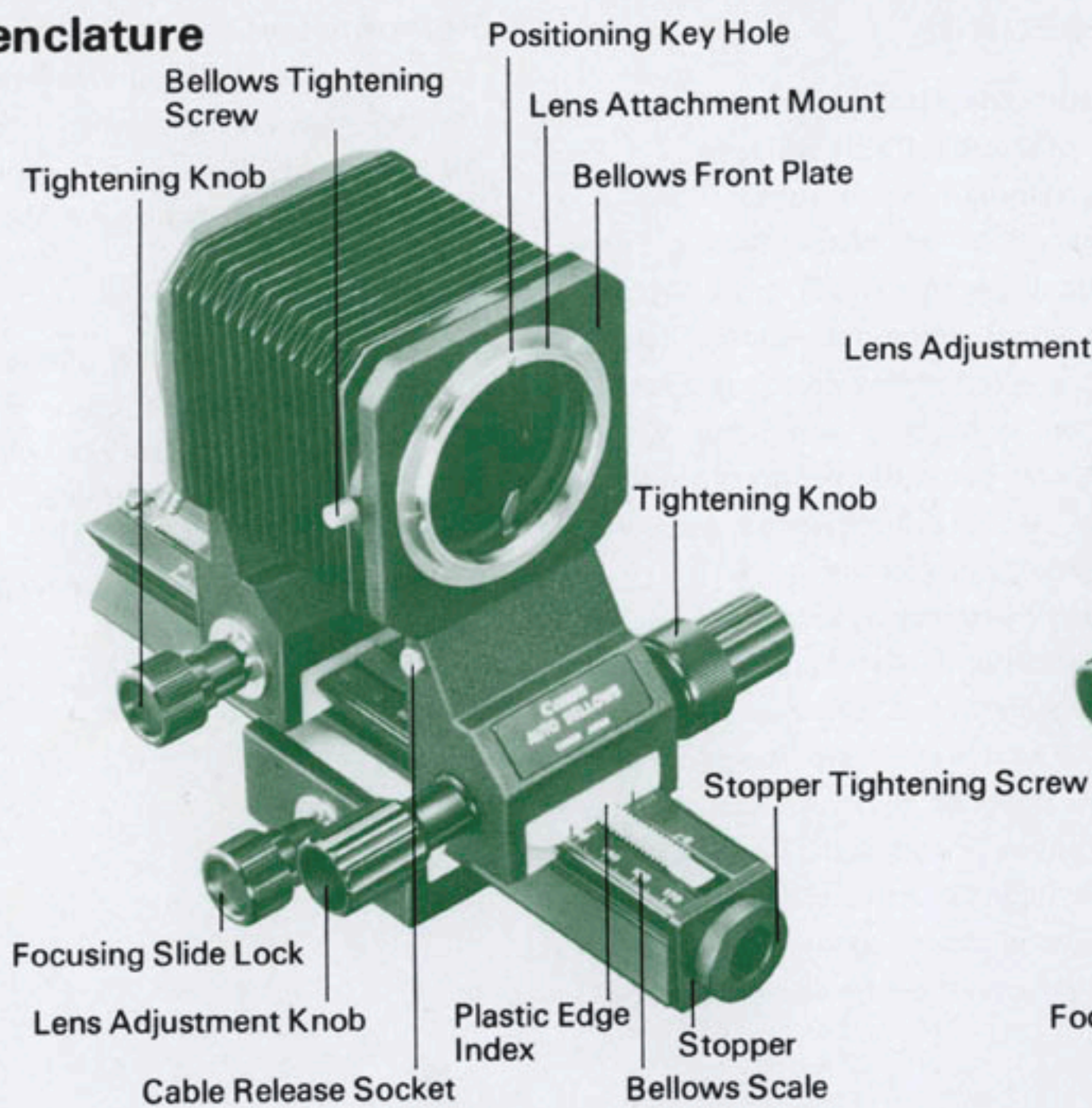

Attachment to the Camera

1. Rotate the body attachment lever downwards until it stops so that the red dot on the body attachment mount is right above the positioning pin.
2. Next align the red dot above the camera mount with the red dot on the bellows' body attachment mount, push the camera body in and rotate the body attachment lever upwards to secure. When removing the camera, rotate this lever in the opposite direction.

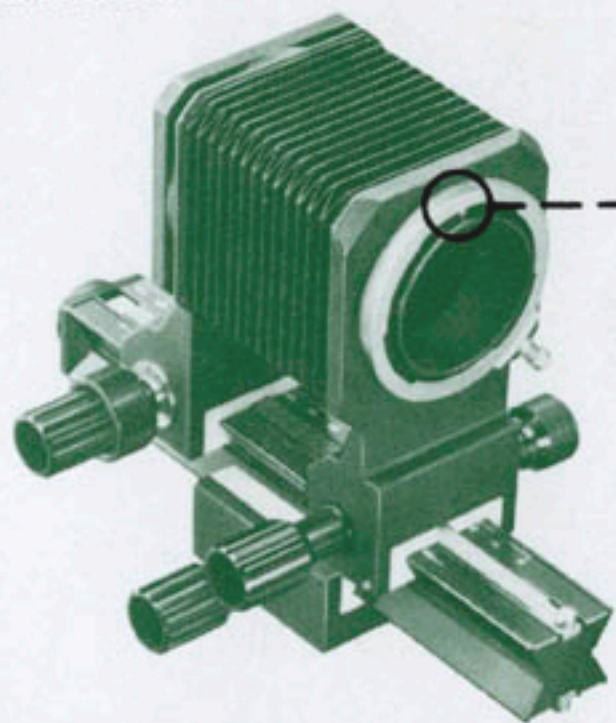

Camera with Winder and Motor Drive Accessories

A camera body with a winder or motor drive accessory can be attached to the bellows. With a winder attached to the camera body, the camera can be secured to the bellows more or less centered on the runner for a horizontal shot. However, with a motor drive accessory, the bellows rear plate should be moved to the rearmost position of the runner for a horizontal shot.



Horizontal/Vertical Change of Camera Position

The camera can be changed from a horizontal to vertical position if the camera body is used alone without a winder or motor drive accessory. It does not matter whether the bellows is more or less centered on the runner or its rear plate moved to the rearmost position. However, when the camera is used with a winder or motor drive accessory, change the camera from a horizontal to vertical position at the rearmost position of the runner. Once the camera is changed to a vertical position with a winder or motor drive attached, the bellows can be moved freely from the rear end to the center of the rail.

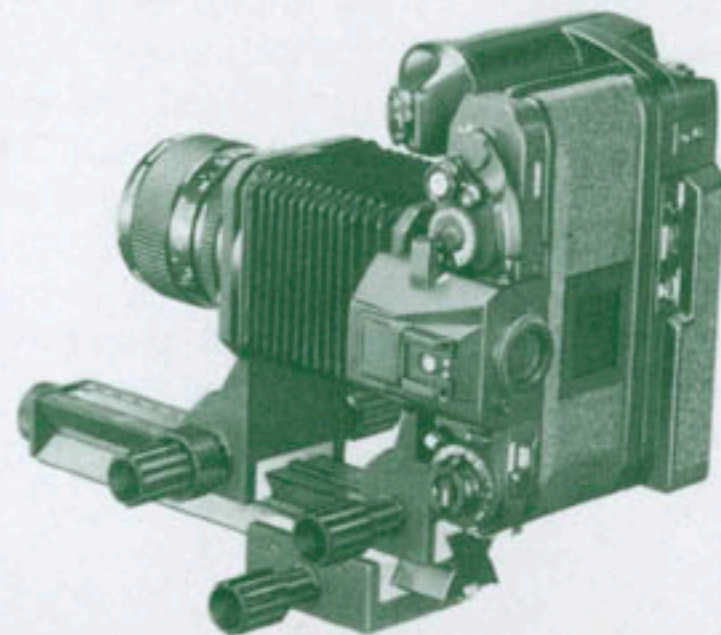

Recommended Lens

For professional results in close-up and photomacrography, Macro and Macrophoto lenses especially designed for close-up and macro work are recommended.

Lens Attachment

The basic method in using the Auto Bellows is to use the Double Cable Release for automatic diaphragm control. The user also has a choice to operate the diaphragm manually by locking the automatic/manual aperture lever in the back of the lens to the manual position. This is possible with FD lenses having a locking collar, Macro 50mm and Macro 100mm lenses. However, for Macro 200mm lens and other compact FD lenses (without the chrome locking collar), manual diaphragm adapter is used to lock the lever to the manual position. See page 7 for the required preparations before actual shooting.

Remove the aperture ring of the lens from the 'A' mark. The lens is attached to the bellows front plate in much the same way the lens is mounted onto the camera body. However, it is important to remember removing the aper-

ture ring of the lens from the 'A' mark beforehand. The lens will not mount if its aperture ring is set at the 'A' mark.

The Procedure for FD Lens with a Locking Collar:

Align the positioning key hole of the bellows with the red dot on the locking collar of the lens. Push the lens straight in and clamp the lens in place by rotating the tightening collar clockwise. Rotate the tightening collar counterclockwise to remove the lens.

The Procedure for FD Lens without a Locking Collar:

Align the positioning key hole of the bellows with the red mount positioning point of the lens and rotate the whole lens clockwise until a click sound is heard. Lens release button springs up to indicate that the lens is firmly clamped. Do not apply pressure on this button while attaching the lens. For dismounting the lens, rotate the lens counterclockwise while pushing in the lens release button.

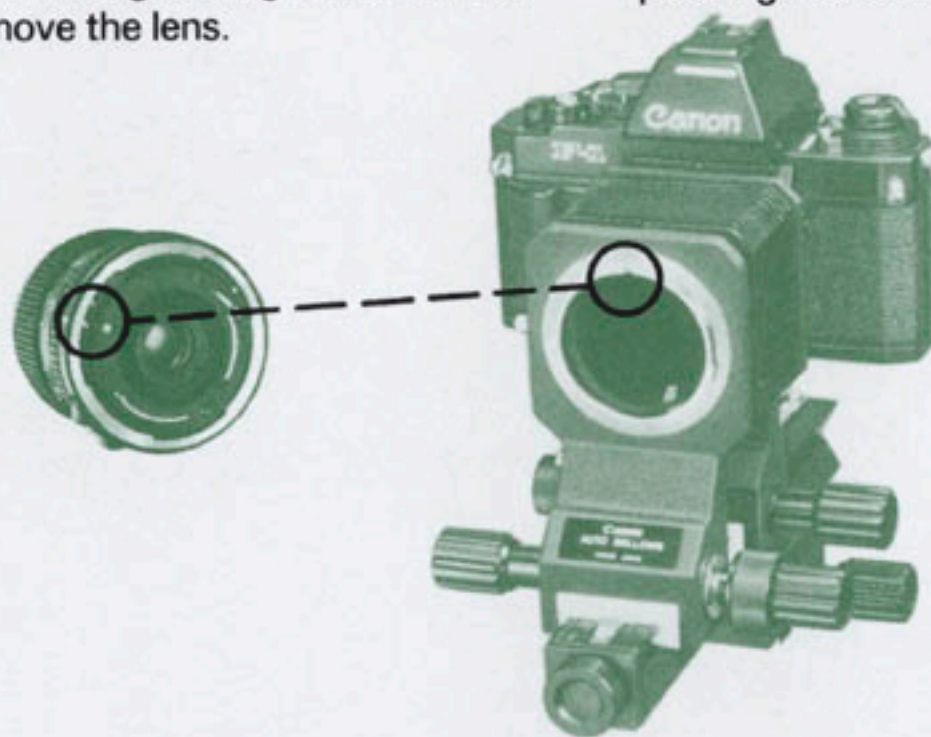

Manual Diaphragm Control

When the Double Cable Release is not used, there is no automatic diaphragm coupling of the lenses. The lens must be closed down manually and the automatic/manual aperture lever of the lens should be locked to the manual position before attaching the lens to the Bellows unit.

For FD lenses having a separate locking collar, turn the automatic/manual aperture lever in the back of the lens counter-clockwise until it locks in the manual position. On the FD 50mm f/1.8 S.C. and the FD 35mm f/3.5 S.C. lenses, an additional locking lever has to be swivelled to lock the automatic/manual aperture lever. The lock position is marked with a red L. The lenses used in these ways on the Bellows give manual operation of the diaphragm. When this function is no longer needed, simply unlock the automatic/manual aperture lever from the manual position.

* For FD lenses without the chrome locking collar, manual diaphragm control is possible only with the 50mm, 100mm Macro lenses (not requiring the use of the manual diaphragm adapter to lock the lever in the manual position) in case the lens is at-

tached directly to the Auto Bellows or other accessories designed to preserve diaphragm automation. When the manual diaphragm adapter is attached to the rear of the FD lenses (which require the use of this adapter to lock the lever in the manual position), do not attempt attaching the lens directly to the Auto Bellows or other accessories designed to preserve diaphragm automation.

Bellows Adjustment

The whole set-up of lens/bellows/camera body can be moved back and forth by turning the focusing slide control. When the approximate distance between the camera and the subject has already been established, the focusing slide control is useful for camera-to-subject distance fine adjustment. The

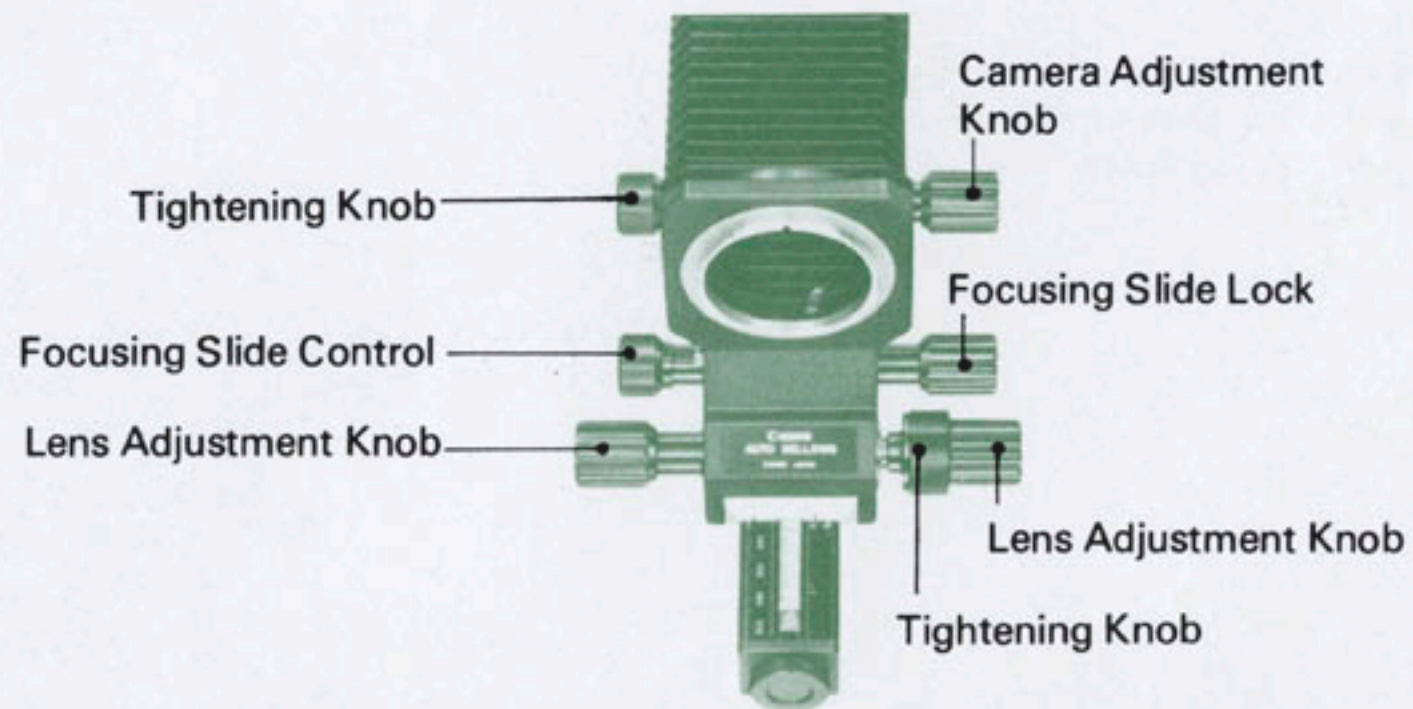

facility to adjust the movement of the whole unit is also useful for proper weight balance when the Bellows unit is mounted on a tripod. The knob on the other side is turned clockwise to lock the movement of the whole unit on the focusing slide.

- * There is a socket for the tripod at the bottom of the Bellows support platform.
- * Incidentally, the Bellows unit can be removed from the sliding base by removing the stopper tightening screw at the front end of the scale. When the Bellows is fitted back so its front now faces the rear of the sliding base, knobs have to be turned in the opposite direction for backward/forward movement. See page 24 for pictures.

Attachment of Canon Double Cable Release

When this double cable release is screwed into the cable release socket on the side of the front plate of the bellows, the diaphragm is automatically coupled and will automatically close down to the preset aperture upon shutter release (see page 11).

If you do not use the double cable release, manual aperture control is necessary. Before you mount the lens, lock the automatic aperture lever at the rear of the FD lenses with a

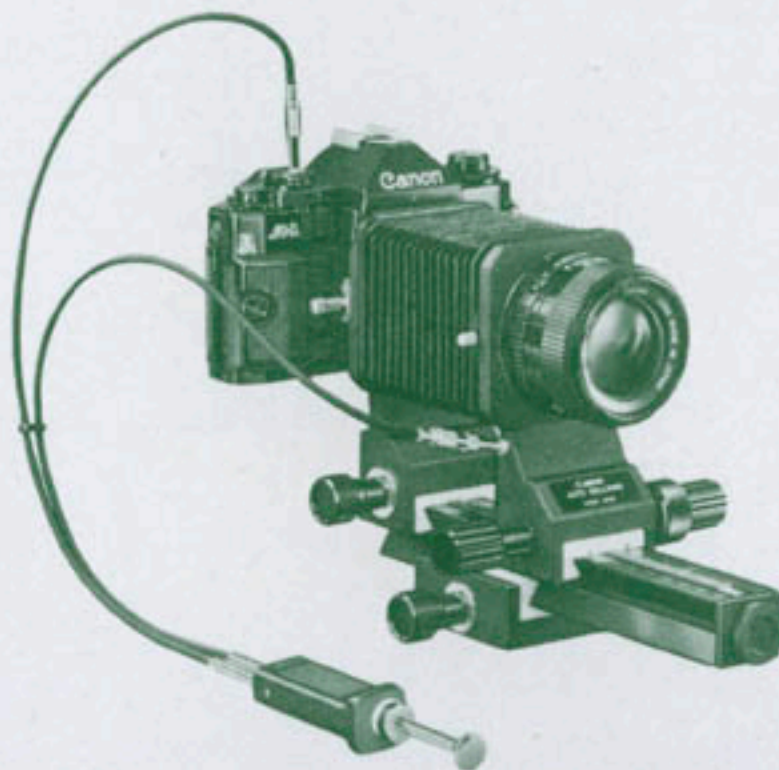

locking collar and FD 50mm and 100mm Macro lenses without a locking collar.

Positioning the Camera on the Bellows

Ordinarily it is best to position the rear plate/camera body at the rear part of the scale so that the front edge of the rear plate is aligned with the "0" mark. This makes it easier to calculate the amount of bellows extension. When the magnification desired calls for only slight bellows extension, set the camera in the middle of the scale. If it is positioned at the rear, there is the possibility of the front end of the bellows bumping against the subject.

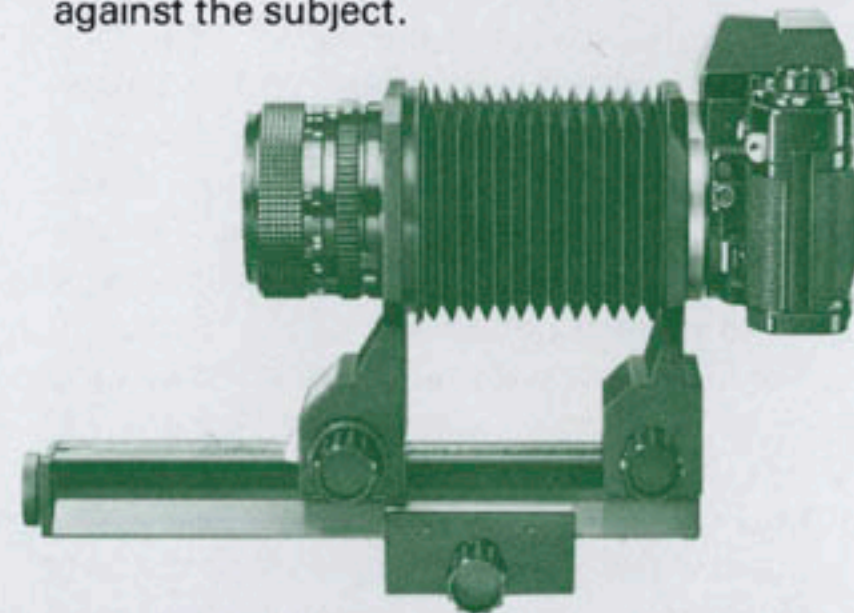

Focusing

Please refer to the tables on pages 16–23. These tables indicate the shooting distance and the required bellows extension for each type of lens according to the desired magnification. First decide the magnification you want, then read the corresponding shooting distance and position the camera. Then adjust the bellows to the specified distance on the bellows scale. For fine adjustments in focus, move the camera/bellows/lens unit as a whole by turning the focusing slide control. The unit can be locked into position by turning the focusing slide lock knob on the support platform.

For more details on calculating image magnification, please refer to page 13.

Explanation of Bellows Scale

There are two scales on the bellows rail. One scale is calibrated in millimeters from 0mm to 175mm and indicates the amount of bellows extension. The shortest optical length on the bellows scale is 39mm. The other scale is calibrated in various image magnifications possible using a 50mm macro lens. The

gradations in the bottom row of this scale (referring to the picture below) indicate image magnifications for a 50mm macro lens mounted onto the bellows in standard direction. The gradations on the top row apply to a 50mm macro lens which is reverse-mounted onto the bellows. Since the image magnification values change with lens focal length, the magnification scale cannot be used with lenses having focal lengths other than 50mm macro lens.

The specific values on both the millimeter and the magnification scales apply to when the rear plate and camera body are positioned at the rear of the scale on "0".

For reverse-mounting the lens, see page 24.

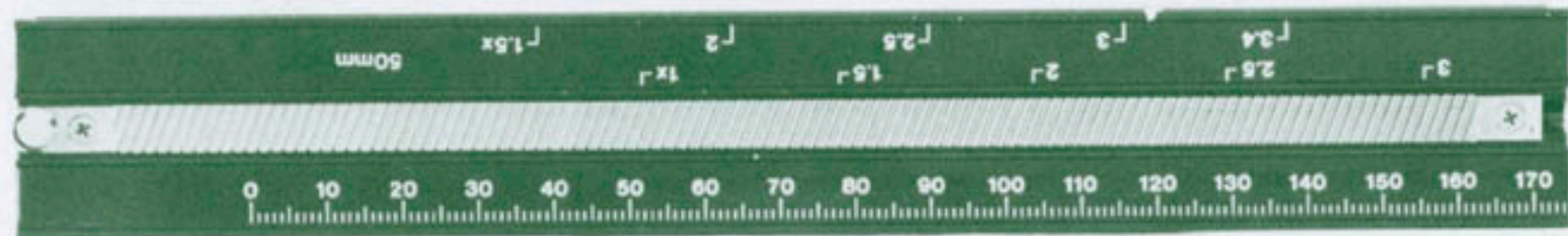

Using the Bellows Scale

The function of the two scales is to indicate how far you should extend the bellows to obtain a desired magnification. When using a 50mm macro lens with the rear plate at the very rear of the bellows rail, simply turn the lens adjustment knob until the edge of the plastic forerunner (with the two red marks) of the front plate is aligned with the magnification desired.

When using other focal length lenses, read the appropriate table for the required bellows extension in millimeters depending on the

magnification desired. Align the slanted plastic edge (with the two red marks) of the front plate with the value in millimeters on the scale.

The slanted plastic edge of the front plate remains the index even when mounted on the bellows in reverse (see page 24).

In situations where it is necessary to position the rear plate with the camera body somewhere in the middle of the scale instead of at the end, add the necessary bellows extension from the appropriate table to the value aligned with the front portion of the rear plate

and move the front plate of the bellows until the plastic edge is aligned with the sum. For example, if the front edge of the rear plate is aligned with 60mm and the necessary bellows extension is 50mm, add 50mm to 60mm to obtain 110mm and align the plastic edge of the front plate with 110mm. When using a 50mm macro lens, you may simplify the process by aligning the front edge of the rear plate with a specific magnification, adding the desired magnification to that value and aligning the edge of the front plate with the sum of the two magnifications.

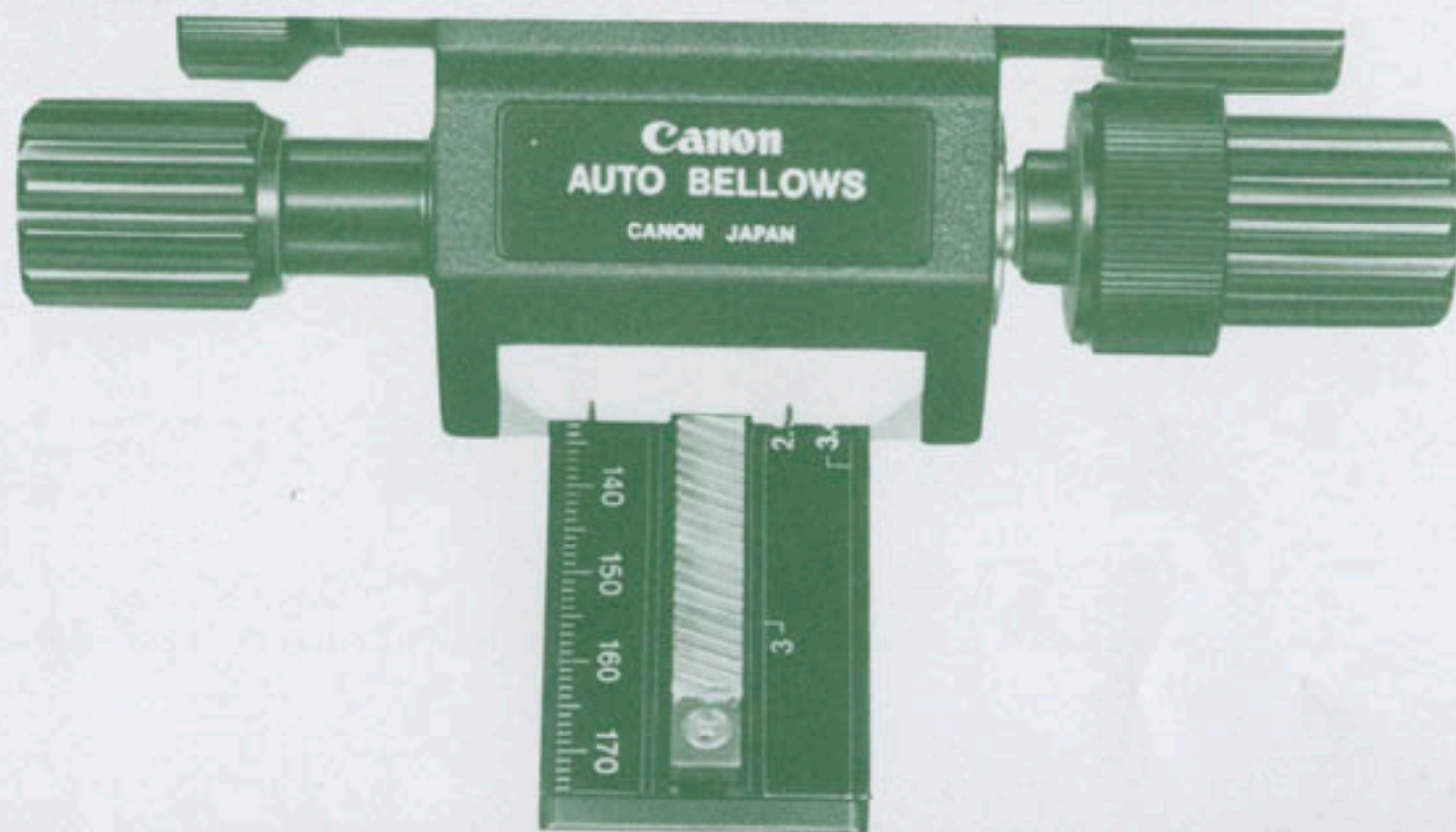

Canon Double Cable Release

The Canon Double Cable Release is an accessory designed for use with the Auto Bellows or the Macro Auto Ring in photomacrography and photomicrography to allow automatic diaphragm coupling of FD and FL lenses. The double cable release has two plungers. At the half stroke of the cable release, the red-coded plunger screwed into the Auto Bellows or Macro Auto Ring closes the lens down to the preset aperture. Macro Auto Ring mounts onto the rear of the lens for preserving the automatic diaphragm function when non-automatic accessory is interposed between the lens and the Auto Bellows and the lens is reversed. This reversed lens/non-automatic accessory combination is used when magnification higher than can be possibly obtained by simply attaching the reversed lens directly to the Auto Bellows is required. At the full stroke of the cable release, the plunger screwed into the camera's shutter release button releases the shutter.

Instructions

1. Adjust the length of the red-coded plunger by turning the lower threaded ring at the lower end of the cable. When used on the Auto Bellows, it should be protruded to its maximum length and for use with the Macro Auto Ring it should be shortened to the minimum length. The plunger length of the supplied Double Cable Release comes adjusted for using it with the Macro Auto Ring.
2. For adjusting the red-coded plunger to its maximum length for using it with the Auto Bellows, first press down the cable release knob all the way down after adjusting the knurled ring at its base upwards in an unlocked position. While holding the affixing ring, slightly loosen the plunger adjustment ring and turn the plunger length adjustment ring clockwise, looking from the front, until it stops. Upon pressing the cable release knob, the plunger will protrude out to its maximum length of about 15mm for completely closing down the diaphragm of the lens attached to the Auto Bellows to the minimum or whatever pre-set aperture. For shortening to the minimum length of

around 9mm for use with the Macro Auto Ring, turn the plunger length adjustment red ring counterclockwise, looking from the front.

3. Screw the red-coded plunger into the cable release socket of the Auto Bellows or Macro Auto Ring by turning the affixing ring and the other plunger into the camera cable release socket.

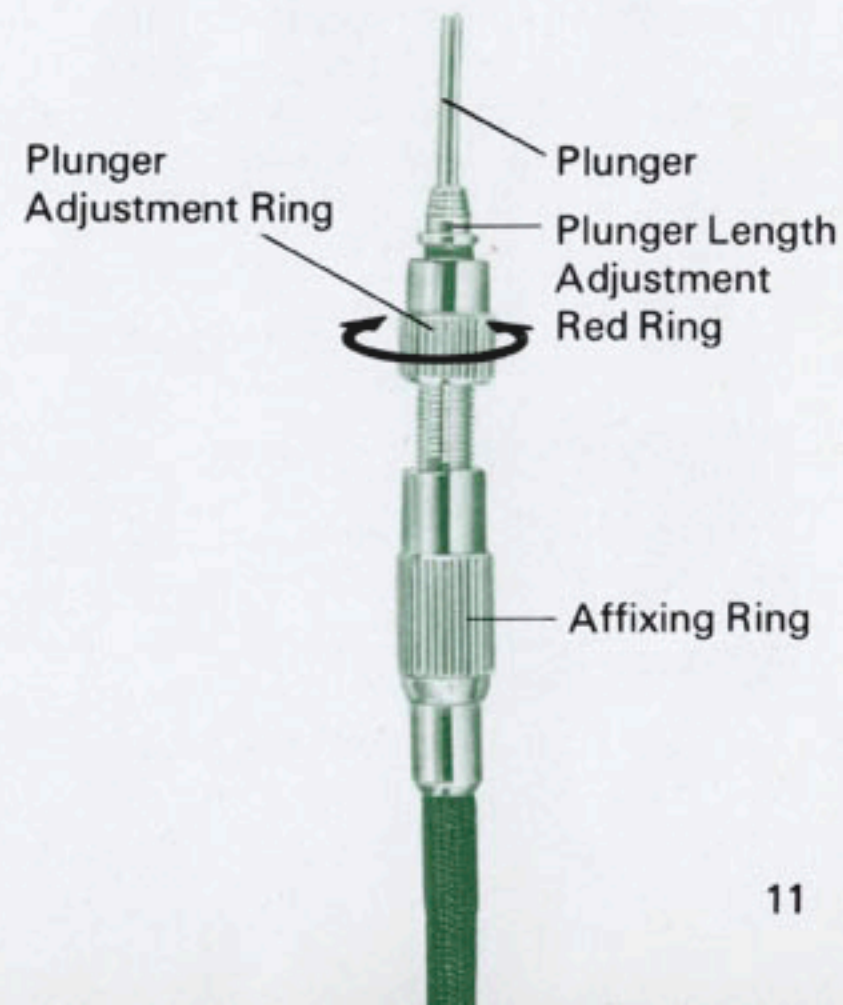

4. Adjust the knurled ring at the base of the cable release knob. This ring has two positions. It can be upwards in an unlocked position or pressed down while turning clockwise where it will lock. Make sure it is in the upwards, unlocked position.
5. Focus at full aperture.
6. Press the cable release knob halfway. The red-coded plunger will protrude to close down the lens to the preset aperture. As long as the knurled ring at the base of the knob is in the upward position, the plunger will be locked in the protruded position to facilitate metering.

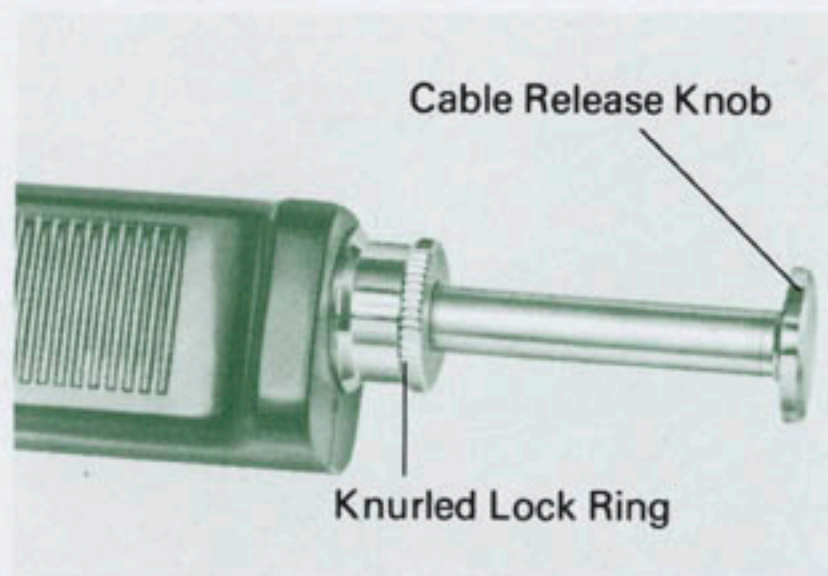

Metering and Releasing the Shutter

1. With cameras such as the AE-1 PROGRAM, AE-1, or A-1, use the exposure preview switch instead of shutter button for metering after closing down the lens to the pre-set aperture. With cameras such as the New F-1 and AV-1 without the exposure preview switch, cable release knob must be pressed slightly down for switching on the meter and taking a reading. If you are not quite ready for a shot at this instance, be careful not to press the cable release knob all the way in or deep enough to prematurely release the shutter.

With cameras such as the New F-1 and AV-1, be especially careful not to prematurely release the shutter as only the shutter button functions as a meter switch and it has to be pressed to get the meter in the switched-on state.

2. Press the cable release knob all the way in to release the shutter.
3. Before winding the film, press down on the knurled ring beneath the cable release knob. The cable release knob will then pop out and the lens will return to full aperture. Be sure to pop out the cable re-

lease knob before advancing the film for the next shot. Otherwise in case of cameras with two-step electromagnetic shutter release such as the AE-1, AE-1 PROGRAM, or A-1, the operation of the winding lever (when you wish to only advance the film) while the shutter button is still being held down by the cable release will release the shutter as well.

- On most cameras, shutter button functions as a meter switch and the weight of the cable release sometimes keeps the meter in the switched-on state between shots. You can prevent this by using a cable holder to take up the slack of the cable release.

Use of Macro FD 50mm f/3.5 and FD 100mm f/4 Lenses

These lenses have aperture lever which if pushed all the way against resistance, locks into the stop-down mode to give manual operation of the diaphragm. Lens returns to full aperture only by turning the aperture ring and therefore Double Cable Release is not used in this instance. Use ordinary cable release instead to release the shutter. Macro FD 50mm f/3.5 and Macro FD 100mm f/4 lenses (without chrome locking collars) are only lenses having aperture lever which locks into the stop-down

mode and if you wish to use Double Cable Release, you must remember to keep the aperture lever in unlocked position.

Simple Photographic Procedure

Refer to your lens instruction booklet and the tables in these instructions while following these steps for shooting.

1. Choose the image magnification.
2. Read the shooting distance corresponding to the image magnification from the table and position the camera accordingly.
Measure the shooting distance from the film plane indicator on the camera body to the subject.
3. Read the bellows scale setting from the table and position the lens by turning the lens adjustment knob.
4. Look into the viewfinder and focus by turning the shooting distance adjustment knob located on the side of the support platform.
5. Set the camera for stopped-down metering function. It means that the stop-down lever (available on some cameras) or stop-down slider (for the New F-1) must be first locked

in the stop-down position. Take a meter reading by using the exposure preview switch or by application of slight pressure on the shutter button. In the case of a non-through-the lens camera, correct the exposure following the exposure factor conversion table. (See page 30.)

6. Press the double cable release all the way to trip the shutter.
7. Press down on the knurled ring beneath the cable release knob to pop out the knob after the shooting.

Obtaining Image Magnification

Image magnification is a ratio between the image size and the object size and can be calculated according to the following formula:

$$M = \frac{y'}{y}$$

M = image magnification

y' = image size

y = object size

Example: If you wish to shoot a flower with a 4cm diameter so that it fills up the entire film frame from top to bottom, the resulting calculations look like the following:

$$\frac{24}{40} = 0.6X$$



* The film frame size of a 35mm camera is 24 × 36mm.

You can also obtain image magnification by using the following formula: $M = \frac{r}{f}$

M = image magnification

f = lens focal length ("f" is a nominal value)

r = lens extension

Exposure

Camera with through-the-lens meter

When the lens is extended away from the camera body by means of accessories such as the bellows, extension tubes, etc., the amount of light reaching the film plane diminishes. Since a camera with a through-the-lens meter measures the light after it comes through the lens, the meter automatically takes the decreased light into account and there is no need to correct exposure. Metering is to be done when the lens is closed down to the pre-set aperture meaning that the lens is used in the stop-down mode. This can be confirmed by darkening of the screen image after pressing the Double Cable Release knob halfway and then turning the aperture ring toward the minimum aperture.

When stopping the lens down to a very small aperture, the light level may be too low for meter coupling. In this case, meter the exposure at maximum aperture, then close the lens down to the desired aperture and figure the necessary shutter speed according to the metered exposure. For example, if you close the lens down three f/stops, reduce the shutter speed by three steps.

Camera without through-the-lens meter

When doing close-up/photomacrography by inserting accessories between the lens and camera body and using a camera without a through-the-lens meter, it is necessary to use a separate meter and to increase the metered exposure. An incident light-reading exposure meter is recommended. The exposure correction must be made according to the total length of all accessories inserted between the lens and the camera body or according to image magnification. The amount of exposure correction is called the exposure factor and can be calculated by using the following equations:

$$1) B=(1+M)^2 \text{ and } 2) M=\frac{r}{f}$$

where

B = exposure factor

f = lens focal length

r = amount of lens extension

M = image magnification

To determine the amount of lens extension, read it from the bellows scale. Add the length of any additional tubes or other accessories which are inserted between the lens and the bellows. The exact lengths of these other accessories may be found on page 32.

Example: If you are using a 50mm lens extending up to 100mm, you can calculate the expo-

sure factor as follows. Using formula 2, the image magnification becomes 2X; putting this answer into formula 1 gives $B=(1+2)^2=9$. In other words, an exposure nine times the metered exposure value must be given. Once you have calculated the exposure factor, make the exposure correction by multiplying the metered shutter speed by the exposure factor.

An easier way to find out how much exposure correction is necessary is to use the exposure factor conversion table included in these instructions. Simply find the exposure factor which corresponds to the image magnification. The table also gives the corresponding amounts of exposure correction in exposure degrees. One exposure degree equals one f/stop or one shutter speed step. Make the exposure correction by opening the diaphragm or reducing the shutter speed by the specified number of exposure degrees or a combination of the two. For instance, using the same above example, and referring to the exposure factor conversion table, the exposure must be increased by 3-1/4 exposure degrees for a magnification of 2X. One way to make this correction is to open the lens three or 3-1/2 f/stops from the metered aperture.

- * To compensate for errors in close-up exposure adjustment, take extra shot each of about one stop more and one stop less from the recommended exposure.

Hints and General Precautions in Close-ups and Photomacrography

1. Focus before metering the exposure. If you are using the camera with stop-down lever or slide, lock the lever or slide in the stop-down position. When using a separate exposure meter, increase the exposure using the figures in the exposure factor conversion table.
2. Whether using a through-the-lens or a separate exposure meter, some exposure correction may be necessary depending upon the subject's tone. If the subject is composed of many white tones, increase the exposure. Decrease the exposure if the subject has many dark tones. This exposure correction must be added to the exposure factor correction made when using a separate exposure meter.
3. Depth of field becomes very shallow in high-magnification photography. Close the diaphragm down to at least f/5.6 and

make any necessary corrections in exposure by reducing the shutter speed rather than opening the aperture.

When using an ordinary lens, it is also necessary to use a small aperture to eliminate aberrations due to abnormally close shooting distances. Canon macro and macrophoto lenses are specially corrected against these aberrations, but using a small aperture is still recommended for good depth of field. If it becomes too dark to meter or if the shutter speed becomes too slow, raise the light level.

4. The least bit of camera shake results in exaggerated image blur in high-magnification photography. Make sure the shooting site is vibration-free. Always use a tripod or copy stand and a cable release.
5. In case of higher magnification, image cut-off in the viewfinder sometimes occurs but it does not affect the exposed image.

With FD lens without a locking collar attached in standard direction to Auto Bellows (focusing ring at infinity)

Lens		Bellows Extension (mm)																
		39	40	50	60	70	80	90	100	110	120	130	140	150	160	170	175	175★
FD35mm f/2	Shooting Distance (mm)	153	154	159	165	173	181	189	198	207	216	225	235	244	254	263	268	274
	Magnification	1.1	1.1	1.4	1.7	2.0	2.3	2.5	2.8	3.1	3.4	3.7	3.9	4.2	4.5	4.8	4.9	5.1
	Field of View (mm)	22×33	21×32	17×26	14×21	12×18	11×16	9×14	9×13	8×12	7×11	7×10	6×9	6×9	5×8	5×8	5×7	5×7
FD35mm f/2.8	Shooting Distance (mm)	153	153	157	163	170	178	186	195	204	213	222	231	241	250	260	264	270
	Magnification	1.1	1.1	1.4	1.7	2	2.3	2.5	2.8	3.1	3.4	3.7	4	4.3	4.5	4.8	5	5.1
	Field of View (mm)	22×33	21×32	17×25	14×21	12×18	11×16	9×14	8×13	8×12	7×11	7×10	6×9	6×8	5×8	5×7	5×7	5×7
FD50mm f/1.2	Shooting Distance (mm)	197	196	193	194	197	203	209	216	223	231	240	248	257	266	275	280	286
	Magnification	0.8	0.8	1.0	1.2	1.4	1.6	1.7	2.0	2.1	2.3	2.5	2.7	2.9	3.1	3.3	3.4	3.5
	Field of View (mm)	32×48	31×46	25×37	21×31	18×27	15×23	14×21	12×19	11×17	10×15	10×14	9×13	8×12	8×12	7×11	7×11	7×10
FD50mm f/1.4	Shooting Distance (mm)	197	196	193	194	198	203	209	216	224	232	240	248	257	266	275	280	287
	Magnification	0.8	0.8	1	1.2	1.4	1.6	1.7	1.9	2.1	2.3	2.5	2.7	2.9	3.1	3.3	3.4	3.5
	Field of View (mm)	32×48	31×46	25×37	21×31	18×26	15×23	14×21	12×19	11×17	10×15	10×14	9×13	8×12	8×12	7×11	7×11	7×10
FD50mm f/1.8	Shooting Distance (mm)	201	201	197	198	202	207	214	221	228	236	244	253	262	271	280	284	289
	Magnification	0.8	0.8	1	1.2	1.4	1.5	1.7	1.9	2.1	2.3	2.5	2.7	2.9	3.1	3.3	3.4	3.5
	Field of View (mm)	32×48	31×46	25×37	21×31	18×27	15×23	14×21	12×19	11×17	10×15	10×14	9×13	8×12	8×12	7×11	7×11	7×10
FD50mm f/3.5 Macro	Shooting Distance (mm)	210	209	206	207	211	216	222	229	237	245	253	261	270	279	288	293	317
	Magnification	0.8	0.8	1	1.2	1.4	1.5	1.7	1.9	2.1	2.3	2.5	2.7	2.9	3.1	3.3	3.4	3.9
	Field of View (mm)	32×48	31×46	25×37	21×31	18×27	16×23	14×21	12×19	11×17	10×16	10×14	9×13	8×12	8×12	7×11	7×11	6×9

★ When focusing ring fully extended.

* The FD 35mm f/2 incorporates a "floating" system for performance at close focusing and all the data here are based on the results obtained when the focusing ring is fully extended.

With FD lens without a locking collar attached in standard direction to Auto Bellows (focusing ring at infinity)

Lens		Bellows Extension(mm)																
		39	40	50	60	70	80	90	100	110	120	130	140	150	160	170	175	175★
FD85mm f/1.8	Shooting Distance (mm)	376	372	347	334	327	324	324	327	330	335	340	346	353	360	367	371	379
	Magnification	0.5	0.5	0.6	0.7	0.8	1	1.1	1.2	1.3	1.4	1.5	1.7	1.8	1.9	2	2.1	2.2
	Field of View (mm)	52×78	50×76	40×60	34×50	29×43	25×38	22×34	20×30	18×27	17×25	16×23	14×22	13×20	13×19	12×18	12×17	11×16
FD100mm f/2.8	Shooting Distance (mm)	492	486	446	443	409	401	397	396	396	399	402	407	412	418	424	428	436
	Magnification	0.4	0.4	0.5	0.6	0.7	0.8	0.9	1	1.1	1.2	1.3	1.4	1.5	1.6	1.7	1.7	1.9
	Field of View (mm)	62×93	60×90	48×72	40×60	34×52	30×45	27×40	24×36	22×33	20×30	19×28	17×26	16×24	15×23	14×21	14×21	13×19
FD100mm f/4 Macro	Shooting Distance (mm)	496	491	451	427	413	405	401	400	401	403	407	411	416	422	429	432	469
	Magnification	0.4	0.4	0.5	0.6	0.7	0.8	0.9	1	1.1	1.2	1.3	1.4	1.5	1.6	1.7	1.7	2.2
	Field of View (mm)	62×93	60×90	48×72	40×60	34×52	30×45	27×40	24×36	22×33	20×30	19×28	17×26	16×24	15×23	14×21	14×21	11×16
FD135mm f/2.8	Shooting Distance (mm)	784	773	692	642	608	586	571	561	554	550	549	549	550	552	556	558	566
	Magnification	0.3	0.3	0.4	0.4	0.5	0.6	0.7	0.7	0.8	0.9	1	1	1	1.2	1.3	1.3	1.4
	Field of View (mm)	83×124	81×121	65×97	54×81	46×69	40×61	36×54	32×49	29×44	27×40	25×37	23×35	22×32	20×30	19×29	18×28	17×25
FD135mm f/3.5	Shooting Distance (mm)	771	761	680	630	597	575	560	550	544	540	538	538	539	542	546	548	556
	Magnification	0.3	0.3	0.4	0.4	0.5	0.6	0.7	0.7	0.8	0.9	1	1	1.1	1.2	1.3	1.3	1.4
	Field of View (mm)	82×124	81×121	64×97	54×81	46×69	40×60	36×54	32×48	29×44	27×40	25×37	23×35	21×32	20×30	19×28	18×28	17×25
FD200mm f/4 Macro	Shooting Distance (mm)	1392	1368	1184	1064	981	922	878	844	819	799	784	773	765	758	754	752	678
	Magnification	0.2	0.2	0.3	0.3	0.4	0.4	0.5	0.5	0.6	0.6	0.7	0.7	0.8	0.8	0.9	0.9	2.3
	Field of View (mm)	121×182	118×177	95×142	79×118	68×101	59×89	53×79	47×71	43×65	39×59	36×55	34×51	32×47	30×44	28×42	27×41	10×16

★When focusing ring fully extended.

With FD lens without a locking collar attached in standard direction to Auto Bellows (focusing ring at infinity)

Bellows Extension (mm) (in.)		Lens																
		39	40	50	60	70	80	90	100	110	120	130	140	150	160	170	175	175★
FD35mm f/2	Shooting Distance (in.)	6	6 - 1/16	6 - 1/4	6 - 1/2	6 - 13/16	7 - 1/8	7 - 7/16	7 - 13/16	8 - 1/8	8 - 1/2	8 - 7/8	9 - 1/4	9 - 5/8	10	10 - 3/8	10 - 9/16	10 - 13/16
	Magnification Field of View (in.)	1.1 7/8 × 1 - 5/16	1.1 1 1/8 × 1 - 1/4	1.4 1 1/8 × 1	1.7 9/8 × 1 1/16	2.0 1 1/2 × 1 1/16	2.3 7/8 × 5/8	2.5 3/8 × 9/8	2.8 3/8 × 1/2	3.1 5/8 × 1/2	3.4 1/4 × 7/16	3.7 1/4 × 3/8	3.9 1/4 × 3/8	4.2 1/4 × 3/8	4.5 3/16 × 5/16	4.8 3/16 × 5/16	4.9 3/16 × 1/4	5.1 3/16 × 1/4
FD35mm f/2.8	Shooting Distance (in.)	6 - 1/16	6 - 1/16	6 - 3/16	6 - 7/16	6 - 11/16	7	7 - 5/16	7 - 11/16	8	8 - 3/8	8 - 3/4	9 - 1/8	9 - 1/2	9 - 13/16	10 - 1/4	10 - 7/16	10 - 5/8
	Magnification Field of View (in.)	1.1 7/8 × 1 - 5/16	1.1 1 1/8 × 1 - 1/4	1.4 1 1/8 × 1	1.7 9/8 × 1 1/16	2 1 1/2 × 1 1/16	2.3 7/8 × 5/8	2.5 3/8 × 9/8	2.8 5/8 × 1/2	3.1 5/8 × 7/16	3.4 1/4 × 7/16	3.7 1/4 × 3/8	4 1/4 × 3/8	4.3 1/4 × 5/16	4.5 3/16 × 5/16	4.8 3/16 × 5/16	5 3/16 × 5/16	5.1 3/16 × 5/16
FD50mm f/1.2	Shooting Distance (in.)	7 - 3/4	7 - 11/16	7 - 9/16	7 - 5/8	7 - 3/4	8	8 - 1/4	8 - 1/2	8 - 13/16	9 - 1/8	9 - 7/16	9 - 3/4	10 - 1/8	10 - 1/2	10 - 13/16	11	11 - 1/4
	Magnification Field of View (in.)	0.8 1 - 1/4 × 1 - 7/8	0.8 1 - 3/8 × 1 - 1/8	1.0 1 × 1 - 7/16	1.2 1 1/8 × 1 - 3/16	1.4 1 1/8 × 1 - 1/16	1.6 5/8 × 1 1/8	1.7 9/8 × 1 1/8	2.0 1/2 × 3/4	2.1 7/16 × 1 1/16	2.3 3/8 × 5/8	2.5 3/8 × 9/8	2.7 3/8 × 1/2	2.9 5/16 × 1/2	3.1 5/16 × 7/16	3.3 5/16 × 7/16	3.4 5/16 × 7/16	3.5 1/4 × 7/16
FD50mm f/1.4	Shooting Distance (in.)	7 - 3/4	7 - 11/16	7 - 9/16	7 - 5/8	7 - 3/4	8	8 - 1/4	8 - 1/2	8 - 13/16	9 - 1/8	9 - 7/16	9 - 13/16	10 - 1/8	10 - 1/2	10 - 13/16	11	11 - 5/16
	Magnification Field of View (in.)	0.8 1 - 1/4 × 1 - 7/8	0.8 1 - 3/8 × 1 - 1/8	1 1 × 1 - 7/16	1.2 1 1/8 × 1 - 3/16	1.4 1 1/8 × 1 - 1/16	1.6 5/8 × 1 1/8	1.7 9/8 × 1 1/8	1.9 1/2 × 3/4	2.1 7/16 × 1 1/16	2.3 3/8 × 5/8	2.5 3/8 × 9/8	2.7 3/8 × 1/2	2.9 5/16 × 1/2	3.1 5/16 × 7/16	3.3 5/16 × 7/16	3.4 5/16 × 7/16	3.5 1/4 × 7/16
FD50mm f/1.8	Shooting Distance (in.)	8 - 1/16	7 - 15/16	7 - 3/4	7 - 13/16	7 - 15/16	8 - 3/16	8 - 7/16	8 - 11/16	9	9 - 5/16	9 - 5/8	9 - 15/16	10 - 5/16	10 - 5/8	11	11 - 3/16	11 - 3/8
	Magnification Field of View (in.)	0.8 1 - 1/4 × 1 - 7/8	0.8 1 - 1/4 × 1 - 1/8	1 1 × 1 - 7/16	1.2 1 1/8 × 1 - 1/4	1.4 1 1/8 × 1 - 1/16	1.5 5/8 × 1 1/8	1.7 9/8 × 1 1/8	1.9 1/2 × 3/4	2.1 7/16 × 1 1/16	2.3 7/16 × 5/8	2.5 3/8 × 9/8	2.7 3/8 × 1/2	2.9 5/16 × 1/2	3.1 5/16 × 7/16	3.3 5/16 × 7/16	3.4 5/16 × 7/16	3.5 1/4 × 7/16
FD50mm f/3.5 Macro	Shooting Distance (in.)	8 - 1/4	8 - 1/4	8 - 1/8	8 - 1/8	8 - 5/16	8 - 1/2	8 - 3/4	9	9 - 5/16	9 - 5/8	9 - 5/16	10 - 5/16	10 - 5/8	11	11 - 5/16	11 - 1/2	11 - 7/16
	Magnification Field of View (in.)	0.8 1 - 1/4 × 1 - 7/8	0.8 1 - 1/4 × 1 - 1/8	1 1 × 1 - 7/16	1.2 1 1/8 × 1 - 1/4	1.4 1 1/8 × 1 - 1/16	1.5 5/8 × 5/8	1.7 9/8 × 1 1/8	1.9 1/2 × 3/4	2.1 7/16 × 1 1/16	2.3 7/16 × 5/8	2.5 3/8 × 9/8	2.7 3/8 × 1/2	2.9 5/16 × 1/2	3.1 5/16 × 7/16	3.3 5/16 × 7/16	3.4 5/16 × 7/16	3.9 1/4 × 7/16

★ When focusing ring fully extended.

With FD lens without a locking collar attached in standard direction to Auto Bellows (focusing ring at infinity)

Lens		Bellows Extension(mm)																
		(in.)																
		39	40	50	60	70	80	90	100	110	120	130	140	150	160	170	175	175★
		1-1/2	1-9/16	1-15/16	2-3/8	2-3/4	3-1/8	3-9/16	3-15/16	4-3/4	4-3/4	5-3/4	5-1/8	5-1/2	6-7/8	6-7/8	6-7/8	6-7/8
FD85mm f/1.8	Shooting Distance(in.)	1'-2 13/16	1'-2 11/16	1'-1 11/16	1'-1 1/8	1'-7/8	1'-3/4	1'-7/8	1'-1	1'-1	1'-1 3/16	1'-1 3/8	1'-1 5/8	1'-1 7/8	1'-2 3/16	1'-2 7/16	1'-2 5/8	1'-2 13/16
	Magnification	0.5	0.5	0.6	0.7	0.8	1	1.1	1.2	1.3	1.4	1.5	1.7	1.8	1.9	2	2.1	2.2
	Field of View(in.)	2-1/16 x 3-1/16	2 x 3	1-9/16 x 2-3/8	1-5/16 x 2	1-1/8 x 1-11/16	1 x 1-1/2	7/8 x 1-5/16	11/16 x 1-3/16	3/4 x 1-1/16	11/16 x 1	5/8 x 5/16	9/16 x 7/8	1/2 x 13/16	1/2 x 3/4	7/16 x 11/16	7/16 x 11/16	7/16 x 5/8
FD100mm f/2.8	Shooting Distance(in.)	1'-7 3/8	1'-7 1/8	1'-5 9/16	1'-4 5/8	1'-4 1/16	1'-3 3/4	1'-3 5/8	1'-3 9/16	1'-3 5/8	1'-3 11/16	1'-3 11/16	1'-4	1'-4 1/4	1'-4 7/16	1'-4 11/16	1'-4 11/16	1'-5 3/16
	Magnification	0.4	0.4	0.5	0.6	0.7	0.8	0.9	1	1.1	1.2	1.3	1.4	1.5	1.6	1.7	1.7	1.9
	Field of View(in.)	2-7/16 x 3-5/8	2-1/16 x 3-9/16	1-7/8 x 2-11/16	1-9/16 x 2-1/2	1-3/8 x 2	1-3/16 x 1-3/4	1-1/16 x 1-9/16	11/16 x 1-7/16	7/8 x 1-5/16	11/16 x 1-3/16	3/4 x 1-1/16	11/16 x 1	5/8 x 13/16	9/16 x 7/8	9/16 x 13/16	9/16 x 13/16	1/2 x 3/4
FD100mm f/4 Macro	Shooting Distance(in.)	1'-7 9/16	1'-7 5/16	1'-5 3/4	1'-4 13/16	1'-4 1/4	1'-3 15/16	1'-3 11/16	1'-3 3/4	1'-3 3/4	1'-3 7/8	1'-4	1'-4 3/16	1'-4 3/8	1'-4 5/8	1'-4 7/8	1'-5	1'-6 1/2
	Magnification	0.4	0.4	0.5	0.6	0.7	0.8	0.9	1	1.1	1.2	1.3	1.4	1.5	1.6	1.7	1.7	2.2
	Field of View(in.)	2-7/16 x 3-5/8	2-3/8 x 3-9/16	1-7/8 x 2-7/8	1-9/16 x 2-3/8	1-3/8 x 2-1/16	1-3/16 x 1-3/4	1-1/16 x 1-9/16	5/16 x 1-7/16	7/8 x 1-5/16	11/16 x 1-3/16	3/4 x 1-1/8	11/16 x 1	5/8 x 13/16	9/16 x 7/8	9/16 x 13/16	9/16 x 13/16	7/16 x 5/8
FD135mm f/2.8	Shooting Distance(in.)	2'-6 7/8	2'-6 7/16	2'-3 1/4	2'-1 1/4	1'-11 15/16	1'-11 11/16	1'-10 1/2	1'-10 1/16	1'-9 13/16	1'-9 11/16	1'-9 5/8	1'-9 5/8	1'-9 5/8	1'-9 3/4	1'-9 7/8	1'-9 15/16	1'-10 5/16
	Magnification	0.3	0.3	0.4	0.4	0.5	0.6	0.7	0.7	0.8	0.9	1	1	1	1.2	1.3	1.3	1.4
	Field of View(in.)	3-1/4 x 4-7/8	3-3/16 x 4-3/4	2-9/16 x 3-11/16	2-1/8 x 3-3/16	1-11/16 x 2-3/4	1-9/16 x 2-3/8	1-7/16 x 2-1/8	1-1/4 x 1-15/16	1-3/16 x 1-3/4	1-1/16 x 1-9/16	1 x 1-1/2	11/16 x 1-3/8	7/8 x 1-1/4	11/16 x 1-3/16	3/4 x 1-1/8	3/4 x 1-1/16	1/16 x 1
FD135mm f/3.5	Shooting Distance(in.)	2'-6 3/8	2'-5 15/16	2'-2 13/16	2'-1 13/16	1'-11 1/2	1'-10 5/8	1'-10 1/16	1'-9 5/8	1'-9 3/8	1'-9 1/4	1'-9 3/16	1'-9 3/16	1'-9 1/4	1'-9 3/8	1'-9 1/2	1'-9 9/16	1'-9 1/4
	Magnification	0.3	0.3	0.4	0.4	0.5	0.6	0.7	0.7	0.8	0.9	1	1	1.1	1.2	1.3	1.3	1.4
	Field of View(in.)	3-1/4 x 4-7/8	3-3/16 x 4-3/4	2-9/16 x 3-11/16	2-1/8 x 3-3/16	1-11/16 x 2-3/4	1-9/16 x 2-3/8	1-7/16 x 1-1/8	1-1/4 x 1-7/8	1-1/16 x 1-3/4	1-1/16 x 1-9/16	1 x 1-7/16	11/16 x 1-3/8	7/8 x 1-1/4	11/16 x 1-3/16	3/4 x 1-1/8	3/4 x 1-1/16	1/16 x 1
FD200mm f/4 Macro	Shooting Distance(in.)	4'-6 13/16	4'-5 7/8	3'-10 5/8	3'-5 7/8	3'-2 5/8	3'-5/16	2'-10 9/16	2'-9 1/4	2'-8 1/4	2'-7 1/2	2'-6 7/8	2'-6 7/16	2'-6 1/8	2'-5 7/8	2'-5 11/16	2'-5 5/8	2'-2 11/16
	Magnification	0.2	0.2	0.3	0.3	0.4	0.4	0.5	0.5	0.6	0.6	0.7	0.7	0.8	0.8	0.9	0.9	2.3
	Field of View(in.)	4-3/4 x 7-3/16	4-1/16 x 7	3-3/4 x 5-9/16	3-1/8 x 4-11/16	2-11/16 x 4	2-5/16 x 3-1/2	2-1/16 x 3-1/8	1-7/8 x 2-11/16	1-11/16 x 2-9/16	1-9/16 x 2-5/16	1-7/16 x 2-1/8	1-5/16 x 2	1-1/4 x 1-7/8	1-3/16 x 1-3/4	1-1/8 x 1-5/8	1-1/16 x 1-5/8	7/16 x 5/8

★ When focusing ring fully extended.

With FD lens with a locking collar attached in standard direction to Auto Bellows (focusing ring at infinity)

Lens		Bellows Extension(mm)																
		39	40	50	60	70	80	90	100	110	120	130	140	150	160	170	175	175★
FD 35mm f/2 S.S.C.	Shooting Distance (mm)	167	167	172	179	186	194	203	212	221	230	239	248	258	267	277	282	282
	Magnification	1.3	1.3	1.6	1.8	2.1	2.4	2.7	3	3.2	3.5	4	4.1	4.3	4.6	4.9	5	5
	Field of View (mm)	19×29	19×28	15×23	13×20	11×17	10×15	9×13	8×12	7×11	7×10	6×10	6×9	6×8	5×8	5×7	5×7	5×7
FD 35mm f/3.5 S.C.	Shooting Distance (mm)	157	157	161	167	174	182	190	199	207	216	226	235	244	254	263	268	272
	Magnification	1.1	1.1	1.4	1.7	2	2.3	2.5	2.8	3.1	3.4	3.7	3.9	4.2	4.5	4.8	4.9	5
	Field of View (mm)	22×33	21×32	17×26	14×21	12×18	11×16	9×14	9×13	8×12	7×11	7×10	6×9	6×9	5×8	5×8	5×7	5×7
FD 50mm f/1.4 S.S.C.	Shooting Distance (mm)	193	193	189	190	194	199	206	213	220	228	236	245	254	263	272	276	283
	Magnification	0.8	0.8	1	1.2	1.4	1.6	1.7	1.9	2.1	2.3	2.5	2.7	2.9	3.1	3.3	3.4	3.5
	Field of View (mm)	32×48	31×46	25×37	21×31	18×27	15×23	14×21	12×19	11×17	10×15	10×14	9×13	8×12	8×12	7×11	7×11	7×10
FD 50mm f/1.8 S.C.	Shooting Distance (mm)	201	201	197	198	202	207	214	221	228	236	244	253	262	271	280	283	289
	Magnification	0.8	0.8	1	1.2	1.4	1.6	1.7	1.9	2.1	2.3	2.5	2.7	2.9	3.1	3.3	3.4	3.5
	Field of View (mm)	32×48	31×46	25×37	21×31	18×27	15×23	14×21	12×19	11×17	10×15	10×14	9×13	8×12	8×12	7×11	7×11	7×10
FD 50mm f/3.5 S.S.C. Macro	Shooting Distance (mm)	210	209	206	207	211	216	222	229	237	245	253	261	270	279	288	293	317
	Magnification	0.8	0.8	1	1.2	1.4	1.5	1.7	1.9	2.1	2.3	2.5	2.7	2.9	3.1	3.3	3.4	3.9
	Field of View (mm)	32×48	31×46	25×37	21×31	18×27	16×23	14×21	12×19	11×17	10×16	10×14	9×13	8×12	8×12	7×11	7×11	6×9

★When focusing ring fully extended.

*The FD 35mm f/2 S.S.C. incorporates a "floating" system for performance at close focusing and all the data here are based on the results obtained when the focusing ring is fully extended.

With FD lens with a locking collar attached in standard direction to Auto Bellows (focusing ring at infinity)

Bellows Extension(mm)		39	40	50	60	70	80	90	100	110	120	130	140	150	160	170	175	175*
FD 55mm f/1.2 S.S.C.	Shooting Distance (mm)	207	206	201	201	204	209	214	221	228	236	244	252	261	270	279	283	288
	Magnification	0.7	0.7	0.9	1.1	1.3	1.5	1.6	1.8	2	2.2	2.4	2.5	2.7	2.9	3.1	3.2	3.3
	Field of View (mm)	34×51	33×49	26×40	22×33	19×28	16×25	15×22	13×20	12×18	11×16	10×15	9×14	9×13	8×12	8×12	8×11	7×11
FD 85mm f/1.8 S.S.C.	Shooting Distance (mm)	376	372	347	334	327	324	324	327	330	335	340	346	353	360	367	371	379
	Magnification	0.5	0.5	0.6	0.7	0.8	1	1.1	1.2	1.3	1.4	1.5	1.7	1.8	1.9	2	2.1	2.2
	Field of View (mm)	52×78	50×76	40×60	34×50	29×43	25×38	22×34	20×30	18×27	17×25	16×23	14×22	13×20	13×19	12×18	12×17	11×16
FD 100mm f/2.8 S.S.C.	Shooting Distance (mm)	492	491	446	443	409	401	397	396	396	399	402	407	412	418	424	428	436
	Magnification	0.4	0.4	0.5	0.6	0.7	0.8	0.9	1	1.1	1.2	1.3	1.4	1.5	1.6	1.7	1.7	1.9
	Field of View (mm)	62×93	60×90	48×72	40×60	34×52	30×45	27×40	24×36	22×33	20×30	19×28	17×26	16×24	15×23	14×21	14×21	13×19
FD 100mm f/4 S.C. Macro	Shooting Distance (mm)	496	491	451	427	413	405	401	400	401	403	407	411	416	422	429	432	469
	Magnification	0.4	0.4	0.5	0.6	0.7	0.8	0.9	1	1.1	1.2	1.3	1.4	1.5	1.6	1.7	1.7	2.2
	Field of View (mm)	62×93	60×90	48×72	40×60	34×52	30×45	27×40	24×36	22×33	20×30	19×28	17×26	16×24	15×23	14×21	14×21	11×16
FD 135mm f/2.5 S.C.	Shooting Distance (mm)	750	739	658	608	575	552	537	527	520	516	515	515	516	518	522	524	530
	Magnification	0.3	0.3	0.4	0.4	0.5	0.6	0.7	0.7	0.8	0.9	1	1	1.1	1.2	1.3	1.3	1.4
	Field of View (mm)	83×124	81×121	65×97	54×81	46×69	40×61	36×54	32×49	29×44	27×40	25×37	23×35	22×32	20×30	19×29	18×28	17×26

★When focusing ring fully extended.

With FD lens with a locking collar attached in standard direction to Auto Bellows (focusing ring at infinity)

Bellows Extension(mm) (in.)		Lens																
		39 1-1/2	40 1-9/16	50 1-15/16	60 2-3/8	70 2-3/4	80 3-1/8	90 3-9/16	100 3-15/16	110 4-5/16	120 4-3/4	130 5-1/8	140 5-1/2	150 5-7/8	160 6-5/16	170 6-11/16	175 6-7/8	175★ 6-7/8
FD35mm f/3.5S.C.	Shooting Distance(in.)	6-3/16	6-3/16	6-5/16	6-9/16	6-7/8	7-1/8	7-1/2	7-13/16	8-3/16	8-1/2	8-7/8	9-1/4	9-5/8	10	10-3/8	10-9/16	10-1/16
	Magnification	1.1	1.1	1.4	1.7	2	2.3	2.5	2.8	3.1	3.4	3.7	3.9	4.2	4.5	4.8	4.9	5
	Field of View(in.)	7/8 × 1-5/16	13/16 × 1-1/4	11/16 × 1	9/16 × 13/16	1/2 × 3/4	7/16 × 5/8	3/8 × 9/16	5/16 × 1/2	5/16 × 7/16	1/4 × 7/16	1/4 × 3/8	1/4 × 5/8	1/4 × 5/16	3/16 × 5/16	3/16 × 5/16	3/16 × 5/16	3/16 × 1/4
FD35mm f/2 S.S.C.	Shooting Distance(in.)	6-9/16	6-9/16	6-13/16	7-1/16	7-5/16	7-5/8	8	8-5/16	8-11/16	9-1/16	9-3/8	9-4/4	10-1/8	10-1/2	10-7/8	11-1/16	11-1/16
	Magnification	1.3	1.3	1.6	1.8	2.1	2.4	2.7	3	3.2	3.5	4	4.1	4.3	4.6	4.9	5	5
	Field of View(in.)	3/4 × 1-1/8	3/4 × 1-1/8	5/8 × 7/8	1/2 × 3/4	7/16 × 11/16	3/8 × 9/16	3/8 × 1/2	5/16 × 1/2	5/16 × 7/16	1/4 × 3/8	1/4 × 3/8	1/4 × 3/8	3/16 × 5/16	3/16 × 5/16	3/16 × 5/16	3/16 × 1/4	3/16 × 1/4
FD50mm f/3.5S.S.C. Macro	Shooting Distance(in.)	8-1/4	8-1/4	8-1/8	8-1/8	8-5/16	8-1/2	8-3/4	9	9-5/16	9-5/8	9-15/16	10-5/16	10-5/8	11	11-5/16	11-1/2	11-7/16
	Magnification	0.8	0.8	1	1.2	1.4	1.5	1.7	1.9	2.1	2.3	2.5	2.7	2.9	3.1	3.3	3.4	3.9
	Field of View(in.)	1-1/4 × 1-7/8	1-1/4 × 1-13/16	1 × 1-7/16	13/16 × 1-1/4	11/16 × 1-1/16	5/8 × 15/16	9/16 × 13/16	1/2 × 3/4	7/16 × 11/16	7/16 × 5/8	3/8 × 9/16	3/8 × 1/2	5/16 × 1/2	5/16 × 7/16	5/16 × 7/16	1/4 × 7/16	1/4 × 3/8
FD50mm f/1.8S.C.	Shooting Distance(in.)	7-15/16	7-7/8	7-3/4	7-13/16	7-15/16	8-3/16	8-7/16	8-11/16	9	9-15/16	9-5/8	9-15/16	10-5/16	10-5/8	11	11-3/16	11-3/8
	Magnification	0.8	0.8	1	1.2	1.4	1.6	1.7	1.9	2.1	2.3	2.5	2.7	2.9	3.1	3.3	3.4	3.5
	Field of View(in.)	1-1/4 × 1-7/8	1-1/4 × 1-13/16	1 × 1-7/16	13/16 × 1-1/4	11/16 × 1-1/16	5/8 × 15/16	9/16 × 13/16	1/2 × 3/4	7/16 × 11/16	7/16 × 5/8	3/8 × 9/16	3/8 × 1/2	5/16 × 1/2	5/16 × 1/2	5/16 × 7/16	1/4 × 7/16	1/4 × 3/8
FD50mm f/1.4S.S.C.	Shooting Distance(in.)	7-5/8	7-9/16	7-7/16	7-1/2	7-5/8	7-13/16	8-1/16	8-3/8	8-11/16	9	9-5/16	9-5/8	10	10-5/16	10-11/16	10-7/8	11-1/8
	Magnification	0.8	0.8	1	1.2	1.4	1.6	1.7	1.9	2.1	2.3	2.5	2.7	2.9	3.1	3.3	3.4	3.5
	Field of View(in.)	1-1/4 × 1-7/8	1-1/4 × 1-13/16	1 × 1-7/16	13/16 × 1-1/4	11/16 × 1-1/16	5/8 × 15/16	9/16 × 13/16	1/2 × 3/4	7/16 × 11/16	7/16 × 5/8	3/8 × 9/16	3/8 × 1/2	5/16 × 1/2	5/16 × 7/16	5/16 × 7/16	1/4 × 7/16	1/4 × 3/8

★ When focusing ring fully extended.

22 *The FD 35mm f/2 S.S.C. incorporates a "floating" system for performance at close focusing and all the data here are based on the results obtained when the focusing ring is fully extended.

With FD lens with a locking collar attached in standard direction to Auto Bellows (focusing ring at infinity)

Lens		Bellows Extension(mm)		39	40	50	60	70	80	90	100	110	120	130	140	150	160	170	175	175★
		(in.)		1-1/2	1-9/16	1-15/16	2-3/8	2-3/4	3-1/8	3-9/16	3-15/16	4-5/16	4-3/4	5-1/8	5-1/2	5-7/8	6-5/16	6-11/16	6-7/8	6-7/8
FD55mm	Shooting Distance(in.)	8-3/16	8-1/8	7-15/16	7-15/16	8	8-3/16	8-7/16	8-11/16	9	9-5/16	9-5/8	9-15/16	10-1/4	10-5/8	10-15/16	11-1/8	11-3/8	11-3/8	11-3/8
	Magnification	0.7	0.7	0.9	1.1	1.3	1.5	1.6	1.8	2	2.2	2.4	2.5	2.7	2.9	3.1	3.2	3.3	3.3	3.3
	Field of View(in.)	1-5/16 x 2	1-5/16 x 1-9/16	1-1/8 x 1-9/16	7/8 x 1-5/16	3/4 x 1-1/8	5/8 x 1	9/16 x 7/8	1/2 x 3/4	1/2 x 11/16	7/16 x 5/8	3/8 x 5/8	3/8 x 9/16	3/8 x 1/2	5/16 x 1/2	5/16 x 7/16	5/16 x 7/16	5/16 x 7/16	5/16 x 7/16	5/16 x 7/16
FD85mm	Shooting Distance(in.)	1' 2-11/16	1' 2-11/16	1' 1-11/16	1' 1-1/8	1' 7/8	1' 3/4	1' 3/4	1' 7/8	1' 1	1' 1 3/16	1' 1 3/8	1' 1 5/8	1' 1 7/8	1' 2 3/16	1' 2 7/16	1' 2 5/8	1' 2-15/16	1' 2-15/16	1' 2-15/16
	Magnification	0.5	0.5	0.6	0.7	0.8	1	1.1	1.2	1.3	1.4	1.5	1.7	1.8	1.9	2	2.1	2.2	2.2	2.2
	Field of View(in.)	2-1/16 x 3-1/16	2 x 3	1-9/16 x 2-3/8	1-5/16 x 2	1-1/8 x 1-11/16	1 x 1-1/2	7/8 x 1-5/16	13/16 x 1-3/16	3/4 x 1-1/16	11/16 x 1	5/8 x 15/16	9/16 x 7/8	1/2 x 13/16	1/2 x 3/4	7/16 x 11/16	7/16 x 11/16	7/16 x 11/16	7/16 x 5/8	7/16 x 5/8
FD100mm	Shooting Distance(in.)	1' 7-9/16	1' 7-5/16	1' 5 3/4	1' 4 13/16	1' 4 1/4	1' 3 15/16	1' 3 13/16	1' 3 3/4	1' 3 3/4	1' 3 7/8	1' 4	1' 4 3/16	1' 4 3/8	1' 4 5/8	1' 4 7/8	1' 5	1' 6-1/2	1' 6-1/2	1' 6-1/2
	Magnification	0.4	0.4	0.5	0.6	0.7	0.8	0.9	1	1.1	1.2	1.3	1.4	1.5	1.6	1.7	1.7	2.2	2.2	2.2
	Field of View(in.)	2-7/16 x 3-5/8	2-3/8 x 3-9/16	1-7/8 x 2-7/8	1-9/16 x 2-3/8	1-3/8 x 2-1/16	1-3/16 x 1-3/4	1-1/16 x 1-9/16	15/16 x 1-7/16	7/8 x 1-5/16	13/16 x 1-3/16	3/4 x 1-1/8	11/16 x 1	5/8 x 15/16	9/16 x 7/8	9/16 x 13/16	9/16 x 13/16	9/16 x 13/16	7/16 x 5/8	7/16 x 5/8
FD100mm	Shooting Distance(in.)	1' 7-3/8	1' 7-1/8	1' 5 9/16	1' 4 5/8	1' 4 1/16	1' 3 3/4	1' 4 5/8	1' 3 9/16	1' 3 5/8	1' 3 11/16	1' 3 3/16	1' 4	1' 4 1/4	1' 4 7/16	1' 4 11/16	1' 4 13/16	1' 5-3/16	1' 5-3/16	1' 5-3/16
	Magnification	0.4	0.4	0.5	0.6	0.7	0.8	0.9	1	1.1	1.2	1.3	1.4	1.5	1.6	1.7	1.7	1.9	1.9	1.9
	Field of View(in.)	2-7/16 x 3-5/8	2-3/8 x 3-9/16	1-7/8 x 2-11/16	1-9/16 x 2-3/8	1-3/8 x 2	1-3/16 x 1-3/4	1-1/16 x 1-9/16	15/16 x 1-7/16	7/8 x 1-5/16	13/16 x 1-3/16	3/4 x 1-1/16	11/16 x 1	5/8 x 15/16	9/16 x 7/8	9/16 x 13/16	9/16 x 13/16	1/2 x 3/4	1/2 x 3/4	
FD135mm	Shooting Distance(in.)	2' 5-1/2	2' 5-1/8	2' 1 15/16	1' 11 15/16	1-3/8 x 2	1-3/16 x 1-3/4	1-1/16 x 1-9/16	15/16 x 1-7/16	7/8 x 1-5/16	13/16 x 1-3/16	3/4 x 1-1/16	11/16 x 1	5/8 x 15/16	9/16 x 7/8	9/16 x 13/16	9/16 x 13/16	9/16 x 13/16	1' 8-7/8	1' 8-7/8
	Magnification	0.3	0.3	0.4	0.4	0.5	0.6	0.7	0.7	0.8	0.9	1	1	1.1	1.2	1.3	1.3	1.4	1.4	1.4
	Field of View(in.)	3-1/4 x 4-7/8	3-3/16 x 4-3/4	2-9/16 x 3-11/16	2-1/8 x 3-3/16	1-11/16 x 2-3/4	1-9/16 x 2-3/8	1-7/16 x 2-1/8	1-1/4 x 1-13/16	1-3/16 x 1-3/4	1-1/16 x 1-9/16	1 x 1-1/2	15/16 x 1-3/8	7/8 x 1-1/4	13/16 x 1-3/16	3/4 x 1-1/8	3/4 x 1-1/8	11/16 x 1	11/16 x 1	

★ When focusing ring fully extended.

Shooting with the Lens in Reverse

Mounting a regular lens in reverse when shooting with magnifications larger than life-size improves lens performance at abnormally close shooting distances. This is especially true for retro-focus wide-angle lenses. Usually, except sometimes for telephoto lenses, reversing the lens also permits higher magnifications than when the lens is mounted in the normal direction. And automatic diaphragm function is possible even when the lens is reversed, by using the Double Cable Release.

It is possible to reverse the lens on the Auto Bellows by turning the front plate around. Follow these steps:

1. Unscrew and remove the stopper tightening screw and the stopper from the front end of the bellows rail.

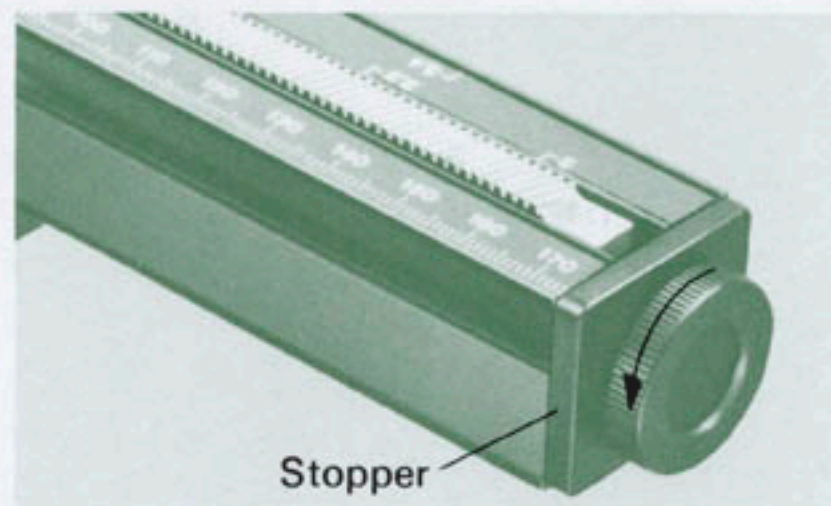

2. Loosen the bellows tightening screw and separate the bellows from the front plate.

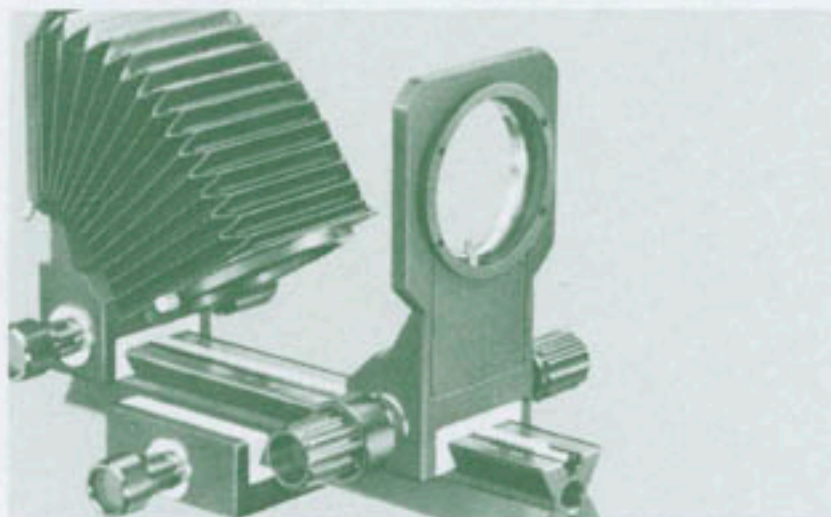

3. Turn the lens adjustment knob to move the front plate forward and pull it off the bellows rail.
4. Turn the front plate around, slide it onto the bellows rail and replace the stopper and the screw.



5. Screw an attachment ring into the lens filter threads. Attachment rings are sold separately in the two diameters of 52mm and 55mm corresponding to the lens filter size.

6. Mount the lens onto the bayonet side of the front plate.
7. Insert the lens with attachment ring into the bellows and tighten the bellows tightening screw.

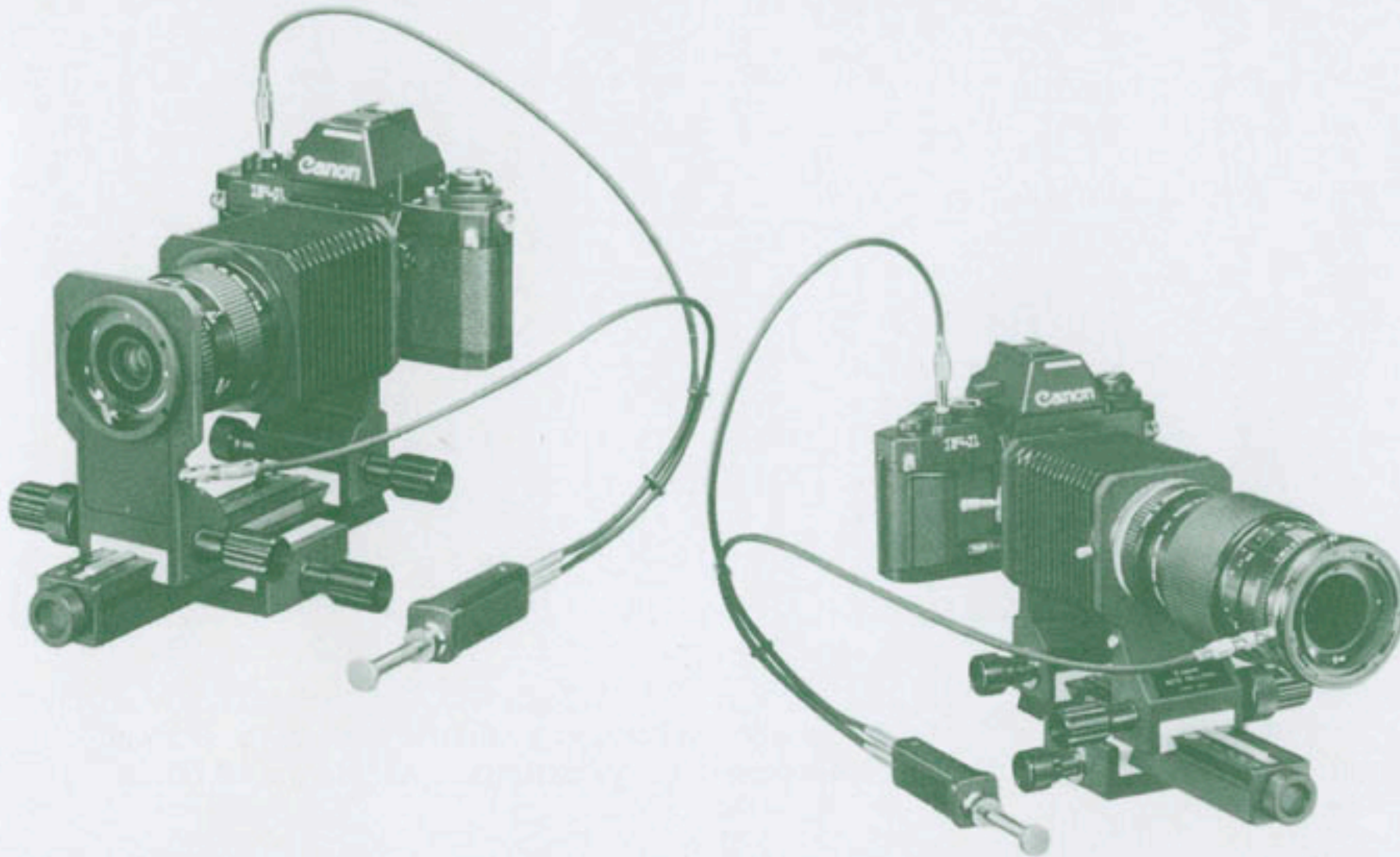

Another Way in Shooting with the Lens in Reverse

The lens can be reverse-mounted and still maintain automatic diaphragm function using different accessory combination and set-up. As shown by the second picture on this page, the front plate of the bellows is not turned around. The red-coded plunger of the Double Cable Release is screwed into the socket of the Macro Auto Ring instead of into the socket of the Auto Bellows. The procedure is as follows:

1. Attach the Macrophoto Coupler FL to the Auto Bellows.
2. Screw the lens (in reverse position) to the Macrophoto Coupler FL (the number such as 52 on this accessory corresponds to the lens filter size).
3. Secure the Macro Auto Ring to the lens mount of the lens.

* Please be careful not to make a mistake in reading the magnification scale when the lens has been reverse-mounted (see page 9).

With FD lens without a locking collar attached in reversed direction to Auto Bellows

The FD 35mm f/2 incorporates a "floating" system for performance at close focusing and all the data here are based on the results obtained when the focusing ring is set at infinity.

Lens		Bellows Extension (mm)													
		10	20	30	40	50	60	70	80	90	100	110	120	130	137
FD35mm f/2 *	Shooting Distance (mm)		179	187	195	204	213	222	231	241	250	260	269	279	286
	Magnification		2.1	2.4	2.7	3	3.3	3.5	3.8	4.1	4.4	4.7	4.9	5.2	5.4
Field of View (mm)			11×17	10×15	9×13	8×12	7×11	7×10	6×9	6×9	5×8	5×8	5×7	6×7	4×7
FD35mm f/2.8 **	Shooting Distance (mm)	170	178	186	195	203	212	222	231	240	250	259	269	279	285
	Magnification	2	2.3	2.5	2.8	3.1	3.4	3.7	4	4	4.5	4.8	5	5.4	5.6
Field of View (mm)		12×18	11×16	9×14	9×13	8×12	7×11	7×10	6×9	6×8	5×8	5×7	5×7	4×7	4×6
FD50mm f/1.2 *	Shooting Distance (mm)		199	204	211	218	226	234	242	251	259	268	277	287	293
	Magnification		1.4	1.6	1.8	2.0	2.2	2.4	2.6	2.8	3.0	3.2	3.3	3.5	3.7
Field of View (mm)			17×26	15×22	13×20	12×18	11×16	10×15	9×14	9×13	8×12	8×11	7×11	7×10	7×10
FD50mm f/1.4 ***	Shooting Distance (mm)	195	199	204	211	218	226	234	242	251	259	268	277	287	293
	Magnification	1.2	1.4	1.6	1.8	2	2.2	2.4	2.6	2.8	3	3.2	3.3	3.5	3.7
Field of View (mm)		20×30	17×26	15×23	13×20	12×18	11×17	10×15	9×14	9×13	8×12	8×11	7×11	7×10	7×10
FD50mm f/1.8 ****	Shooting Distance (mm)	19	20	20	21	21	22	23	24	25	26	26	27	28	29
	Magnification	1.1	1.3	1.5	1.7	1.9	2.1	2.3	2.5	2.7	2.9	3.1	3.3	3.4	3.6
Field of View (mm)		21×32	18×27	16×24	14×21	13×19	11×17	11×16	10×15	9×13	8×13	8×12	7×11	7×10	7×10
FD50mm f/3.5 Macro *****	Shooting Distance (mm)			210	216	222	229	236	244	253	261	2700	2799	2888	2944
	Magnification			1.3	1.5	1.7	1.9	2.1	2.3	2.5	2.7	2.9	3.1	3.3	3.4
Field of View (mm)				18×27	16×23	14×21	12×19	11×17	10×16	10×14	9×13	8×12	8×12	7×11	7×11

* Effective when bellows extension is more than 19.5mm.

*** Effective when bellows extension is more than 14.5mm.

***** Effective when bellows extension is more than 30.5mm.

** Effective when bellows extension is more than 13.5mm.

**** Effective when bellows extension is more than 8.5mm.

With FD lens with a locking collar attached in reversed direction to Auto Bellows

The FD 35mm f/2 S.S.C. incorporates a "floating" system for performance at close focusing and all the data here are based on the results obtained when the focusing ring is set at infinity.

Bellows Extension(mm)		20	30	40	50	60	70	80	90	100	110	120	130	137
FD 35mm f/3.5 S.C. *	Shooting Distance (mm)	179	187	195	204	213	222	231	241	250	260	269	279	286
	Magnification	2.1	2.4	2.7	3	3.3	3.6	3.8	4.1	4.4	4.7	5	5.2	5.4
	Field of View (mm)	11×17	1×15	9×13	8×12	7×11	7×10	6×9	6×9	5×8	5×8	5×7	5×7	4×7
FD 35mm f/2 S.S.C. **	Shooting Distance (mm)		188	196	205	214	223	232	241	250	260	269	279	286
	Magnification		2.2	2.5	2.8	3.1	3.4	3.6	3.9	4.2	4.5	4.8	5.1	5.3
	Field of View (mm)		11×16	10×14	9×13	8×12	7×11	7×10	6×9	6×9	5×8	5×8	5×7	5×7
FD 50mm f/3.5 S.S.C. Macro ***	Shooting Distance (mm)		210	216	222	229	236	244	253	261	270	279	288	294
	Magnification		1.3	1.5	1.7	1.9	2.1	2.3	2.5	2.7	2.9	3.1	3.3	3.4
	Field of View (mm)		18×27	16×23	14×21	12×19	11×17	10×16	10×14	9×13	8×12	8×12	7×11	7×11
FD 50mm f/1.8 S.C. ****	Shooting Distance (mm)	201	206	212	219	227	235	243	251	260	269	278	287	293
	Magnification	1.3	1.5	1.7	1.9	2.1	2.3	2.5	2.7	2.9	3.1	3.3	3.4	3.6
	Field of View (mm)	18×27	16×24	14×21	13×19	11×17	10×16	10×15	9×13	8×13	8×12	7×11	7×10	7×10
FD 50mm f/1.4 S.S.C. *	Shooting Distance (mm)	197	203	210	217	225	233	242	250	259	268	277	286	293
	Magnification	1.5	1.7	1.9	2.1	2.2	2.4	2.6	2.8	3	3.2	3.4	3.6	3.7
	Field of View (mm)	16×24	14×22	13×19	12×18	11×16	10×15	9×14	8×13	8×12	7×11	7×11	7×10	6×10

* Effective when bellows extension is more than 22.5mm.

*** Effective when bellows extension is more than 33mm.

** Effective when bellows extension is more than 33.5mm.

**** Effective when bellows extension is more than 18mm.

With FD lens with a locking collar attached in reversed direction to Auto Bellows

The FD 35mm f/2 S.S.C. incorporates a "floating" system for performance at close focusing and all the data here are based on the results obtained when the focusing ring is set at infinity.

Lens		Bellows Extension(mm) (in.)												
		20 ($1\frac{13}{16}$)	30 ($1\frac{3}{16}$)	40 ($1\frac{9}{16}$)	50 ($1\frac{15}{16}$)	60 ($2\frac{3}{8}$)	70 ($2\frac{3}{4}$)	80 ($3\frac{1}{8}$)	90 ($3\frac{9}{16}$)	100 ($3\frac{15}{16}$)	110 ($4\frac{5}{16}$)	120 ($4\frac{3}{4}$)	130 ($5\frac{1}{8}$)	137 ($5\frac{3}{8}$)
FD35mm f/3.5S.C. *	Shooting Distance(in.)	7	$7\frac{3}{8}$	$7\frac{11}{16}$	8	$8\frac{1}{2}$	$8\frac{3}{4}$	$9\frac{1}{8}$	$9\frac{1}{2}$	$9\frac{7}{8}$	$10\frac{1}{4}$	$10\frac{5}{8}$	11	$11\frac{1}{4}$
	Magnification	2.1	2.4	2.7	3	3.3	3.6	3.8	4.1	4.4	4.7	5	5.2	5.4
	Field of View(in.)	$\frac{7}{16} \times \frac{11}{16}$	$\frac{3}{8} \times \frac{9}{16}$	$\frac{3}{8} \times \frac{1}{2}$	$\frac{5}{16} \times \frac{1}{2}$	$\frac{5}{16} \times \frac{7}{16}$	$\frac{1}{4} \times \frac{3}{8}$	$\frac{1}{4} \times \frac{3}{8}$	$\frac{1}{4} \times \frac{3}{8}$	$\frac{1}{4} \times \frac{3}{8}$	$\frac{3}{6} \times \frac{5}{16}$	$\frac{3}{16} \times \frac{5}{16}$	$\frac{3}{16} \times \frac{5}{16}$	$\frac{3}{16} \times \frac{1}{4}$
FD35mm f/2S.S.C. **	Shooting Distance(in.)		$7\frac{3}{8}$	$7\frac{3}{4}$	$8\frac{1}{16}$	$8\frac{3}{8}$	$8\frac{3}{4}$	$9\frac{1}{8}$	$9\frac{1}{2}$	$9\frac{7}{8}$	$10\frac{1}{4}$	$10\frac{5}{8}$	11	$11\frac{1}{4}$
	Magnification		2.2	2.5	2.8	3.1	3.4	3.6	3.9	4.2	4.5	4.8	5.1	5.3
	Field of View(in.)		$\frac{7}{16} \times \frac{5}{8}$	$\frac{3}{8} \times \frac{9}{16}$	$\frac{5}{16} \times \frac{1}{2}$	$\frac{5}{16} \times \frac{7}{16}$	$\frac{1}{4} \times \frac{7}{16}$	$\frac{1}{4} \times \frac{3}{8}$	$\frac{1}{4} \times \frac{3}{8}$	$\frac{1}{4} \times \frac{3}{8}$	$\frac{1}{4} \times \frac{5}{16}$	$\frac{3}{16} \times \frac{5}{16}$	$\frac{3}{16} \times \frac{5}{16}$	$\frac{3}{16} \times \frac{1}{4}$
FD50mm f/3.5S.S.C. Macro ***	Shooting Distance(in.)		$8\frac{5}{16}$	$8\frac{1}{2}$	$8\frac{3}{4}$	9	$9\frac{5}{16}$	$9\frac{5}{8}$	$9\frac{15}{16}$	$10\frac{1}{4}$	$10\frac{5}{8}$	11	$11\frac{5}{16}$	$11\frac{9}{16}$
	Magnification		1.3	1.5	1.7	1.9	2.1	2.3	2.5	2.7	2.9	3.1	3.3	3.4
	Field of View(in.)		$\frac{11}{16} \times \frac{1}{1\frac{1}{16}}$	$\frac{5}{8} \times \frac{15}{16}$	$\frac{9}{16} \times \frac{13}{16}$	$\frac{1}{2} \times \frac{3}{4}$	$\frac{7}{16} \times \frac{11}{16}$	$\frac{7}{16} \times \frac{5}{8}$	$\frac{3}{8} \times \frac{9}{16}$	$\frac{3}{8} \times \frac{9}{16}$	$\frac{3}{8} \times \frac{1}{2}$	$\frac{5}{16} \times \frac{1}{2}$	$\frac{5}{16} \times \frac{7}{16}$	$\frac{5}{16} \times \frac{7}{16}$
FD50mm f/1.8S.C. ****	Shooting Distance(in.)	$7\frac{15}{16}$	$8\frac{1}{8}$	$8\frac{3}{8}$	$8\frac{5}{8}$	$8\frac{15}{16}$	$9\frac{1}{4}$	$9\frac{9}{16}$	$9\frac{7}{8}$	$10\frac{1}{4}$	$10\frac{9}{16}$	$10\frac{15}{16}$	$11\frac{5}{16}$	$11\frac{9}{16}$
	Magnification	1.3	1.5	1.7	1.9	2.1	2.3	2.5	2.7	2.9	3.1	3.3	3.4	3.6
	Field of View(in.)	$\frac{11}{16} \times \frac{1}{1\frac{1}{16}}$	$\frac{5}{8} \times \frac{15}{16}$	$\frac{9}{16} \times \frac{13}{16}$	$\frac{1}{2} \times \frac{3}{4}$	$\frac{7}{16} \times \frac{11}{16}$	$\frac{7}{16} \times \frac{5}{8}$	$\frac{3}{8} \times \frac{9}{16}$	$\frac{3}{8} \times \frac{9}{16}$	$\frac{3}{8} \times \frac{1}{2}$	$\frac{5}{16} \times \frac{1}{2}$	$\frac{5}{16} \times \frac{7}{16}$	$\frac{5}{16} \times \frac{7}{16}$	$\frac{1}{4} \times \frac{7}{16}$
FD50mm f/1.4S.S.C. *	Shooting Distance(in.)	$7\frac{3}{4}$	8	$8\frac{1}{4}$	$8\frac{9}{16}$	$8\frac{7}{8}$	$9\frac{3}{16}$	$9\frac{1}{2}$	$9\frac{7}{8}$	$10\frac{3}{16}$	$10\frac{9}{16}$	$10\frac{15}{16}$	$11\frac{1}{4}$	$11\frac{1}{2}$
	Magnification	1.5	1.7	1.9	2.1	2.2	2.4	2.6	2.8	3	3.2	3.4	3.6	3.7
	Field of View(in.)	$\frac{5}{8} \times \frac{15}{16}$	$\frac{9}{16} \times \frac{7}{8}$	$\frac{1}{2} \times \frac{3}{4}$	$\frac{7}{16} \times \frac{11}{16}$	$\frac{7}{16} \times \frac{5}{8}$	$\frac{3}{8} \times \frac{9}{16}$	$\frac{3}{8} \times \frac{9}{16}$	$\frac{5}{16} \times \frac{1}{2}$	$\frac{5}{16} \times \frac{7}{16}$	$\frac{5}{16} \times \frac{7}{16}$	$\frac{1}{4} \times \frac{7}{16}$	$\frac{1}{4} \times \frac{3}{8}$	$\frac{1}{4} \times \frac{3}{8}$

* Effective when bellows extension is more than 22.5 mm.

** Effective when bellows extension is more than 33.5mm.

*** Effective when bellows extension is more than 33mm.

**** Effective when bellows extension is more than 18mm.

With FD lens without a locking collar attached in reversed direction to Auto Bellows

The FD 35mm f/2 incorporates a "floating" system for performance at close focusing and all the data here are based on the results obtained when the focusing ring is set at infinity.

Lens		Bellows Extension (mm, (in.))													
		10 ($\frac{3}{8}$)	20 ($\frac{13}{16}$)	30 ($1-\frac{3}{16}$)	40 ($1-\frac{9}{16}$)	50 ($1-\frac{15}{16}$)	60 ($2-\frac{3}{8}$)	70 ($2-\frac{3}{4}$)	80 ($3-\frac{1}{8}$)	90 ($3-\frac{9}{16}$)	100 ($3-\frac{15}{16}$)	110 ($4-\frac{5}{16}$)	120 ($4-\frac{3}{4}$)	130 ($5-\frac{1}{8}$)	137 ($5-\frac{3}{8}$)
FD35mm f/2 *	Shooting Distance (in.) Magnification Field of View (in.)		7- $\frac{1}{16}$ 2.1 $\frac{7}{16} \times \frac{11}{16}$	7- $\frac{3}{8}$ 2.4 $\frac{3}{8} \times \frac{9}{16}$	7- $\frac{11}{16}$ 2.7 $\frac{3}{8} \times \frac{1}{2}$	8 3 $\frac{5}{16} \times \frac{1}{2}$	8- $\frac{3}{8}$ 3.3 $\frac{5}{16} \times \frac{7}{16}$	8- $\frac{3}{4}$ 3.5 $\frac{1}{4} \times \frac{3}{8}$	9- $\frac{1}{8}$ 3.8 $\frac{1}{4} \times \frac{3}{8}$	9- $\frac{1}{2}$ 4.1 $\frac{1}{4} \times \frac{3}{8}$	9- $\frac{7}{8}$ 4.4 $\frac{3}{16} \times \frac{5}{16}$	10- $\frac{1}{4}$ 4.7 $\frac{3}{16} \times \frac{5}{16}$	10- $\frac{5}{8}$ 4.9 $\frac{3}{16} \times \frac{5}{16}$	11 5.2 $\frac{3}{16} \times \frac{1}{4}$	11- $\frac{1}{4}$ 5.4 $\frac{3}{16} \times \frac{1}{4}$
FD35mm f/2.8 **	Shooting Distance (in.) Magnification Field of View (in.)	6- $\frac{11}{16}$ 2 $\frac{1}{2} \times \frac{11}{16}$	7 2.3 $\frac{7}{16} \times \frac{5}{8}$	7- $\frac{5}{16}$ 2.5 $\frac{3}{8} \times \frac{9}{16}$	7- $\frac{11}{16}$ 2.8 $\frac{5}{16} \times \frac{1}{2}$	8 3.1 $\frac{5}{16} \times \frac{7}{16}$	8- $\frac{3}{8}$ 3.4 $\frac{1}{4} \times \frac{7}{16}$	8- $\frac{3}{4}$ 3.7 $\frac{1}{4} \times \frac{3}{8}$	9- $\frac{1}{16}$ 4 $\frac{1}{4} \times \frac{3}{8}$	9- $\frac{9}{16}$ 4 $\frac{1}{4} \times \frac{5}{16}$	9- $\frac{13}{16}$ 4.5 $\frac{3}{16} \times \frac{5}{16}$	10- $\frac{3}{16}$ 4.8 $\frac{3}{16} \times \frac{5}{16}$	10- $\frac{9}{16}$ 5 $\frac{3}{16} \times \frac{1}{4}$	10- $\frac{15}{16}$ 5.4 $\frac{3}{16} \times \frac{1}{4}$	11- $\frac{1}{4}$ 5.6 $\frac{3}{16} \times \frac{1}{4}$
FD50mm f/1.2 *	Shooting Distance (in.) Magnification Field of View (in.)		7- $\frac{13}{16}$ 1.4 $\frac{11}{16} \times 1$	8- $\frac{1}{16}$ 1.6 $\frac{9}{16} \times \frac{7}{8}$	8- $\frac{5}{16}$ 1.8 $\frac{1}{2} \times \frac{13}{16}$	8- $\frac{9}{16}$ 2.0 $\frac{1}{2} \times \frac{11}{16}$	8- $\frac{7}{8}$ 2.2 $\frac{7}{16} \times \frac{5}{8}$	9- $\frac{3}{16}$ 2.4 $\frac{3}{8} \times \frac{5}{8}$	9- $\frac{1}{2}$ 2.6 $\frac{3}{8} \times \frac{9}{16}$	9- $\frac{7}{8}$ 2.8 $\frac{5}{16} \times \frac{1}{2}$	10- $\frac{3}{16}$ 3.0 $\frac{5}{16} \times \frac{1}{2}$	10- $\frac{9}{16}$ 3.2 $\frac{5}{16} \times \frac{7}{16}$	10- $\frac{15}{16}$ 3.3 $\frac{5}{16} \times \frac{7}{16}$	11- $\frac{5}{16}$ 3.5 $\frac{1}{4} \times \frac{3}{8}$	11- $\frac{9}{16}$ 3.7 $\frac{1}{4} \times \frac{3}{8}$
FD50mm f/1.4 ***	Shooting Distance (in.) Magnification Field of View (in.)	7- $\frac{11}{16}$ 1.2 $\frac{13}{16} \times \frac{13}{16}$	7- $\frac{13}{16}$ 1.4 $\frac{11}{16} \times 1$	8- $\frac{1}{16}$ 1.6 $\frac{9}{16} \times \frac{7}{8}$	8- $\frac{5}{16}$ 1.8 $\frac{1}{2} \times \frac{13}{16}$	8- $\frac{9}{16}$ 2 $\frac{1}{2} \times \frac{11}{16}$	8- $\frac{7}{8}$ 2.2 $\frac{7}{16} \times \frac{5}{8}$	9- $\frac{3}{16}$ 2.4 $\frac{3}{8} \times \frac{5}{8}$	9- $\frac{1}{2}$ 2.6 $\frac{3}{8} \times \frac{9}{16}$	9- $\frac{7}{8}$ 2.8 $\frac{5}{16} \times \frac{1}{2}$	10- $\frac{3}{16}$ 3 $\frac{5}{16} \times \frac{1}{2}$	10- $\frac{9}{16}$ 3.2 $\frac{5}{16} \times \frac{7}{16}$	10- $\frac{15}{16}$ 3.3 $\frac{5}{16} \times \frac{7}{16}$	11- $\frac{1}{4}$ 3.5 $\frac{1}{4} \times \frac{3}{8}$	11- $\frac{9}{16}$ 3.7 $\frac{1}{4} \times \frac{3}{8}$
FD50mm f/1.8 ****	Shooting Distance (in.) Magnification Field of View (in.)	7- $\frac{13}{16}$ 1.1 $\frac{13}{16} \times 1-\frac{1}{4}$	7- $\frac{5}{16}$ 1.3 $\frac{11}{16} \times 1-\frac{1}{16}$	8- $\frac{1}{8}$ 1.5 $\frac{5}{8} \times \frac{15}{16}$	8- $\frac{3}{8}$ 1.7 $\frac{9}{16} \times \frac{13}{16}$	8- $\frac{5}{8}$ 1.9 $\frac{1}{2} \times \frac{3}{4}$	8- $\frac{15}{16}$ 2.1 $\frac{7}{16} \times \frac{11}{16}$	9- $\frac{1}{4}$ 2.3 $\frac{7}{16} \times \frac{5}{8}$	9- $\frac{9}{16}$ 2.5 $\frac{3}{8} \times \frac{9}{16}$	9- $\frac{7}{8}$ 2.7 $\frac{3}{8} \times \frac{1}{2}$	10- $\frac{1}{4}$ 2.9 $\frac{5}{16} \times \frac{1}{2}$	10- $\frac{9}{16}$ 3.1 $\frac{5}{16} \times \frac{7}{16}$	10- $\frac{15}{16}$ 3.3 $\frac{5}{16} \times \frac{7}{16}$	11- $\frac{5}{16}$ 3.4 $\frac{1}{4} \times \frac{7}{16}$	11- $\frac{9}{16}$ 3.6 $\frac{1}{4} \times \frac{3}{8}$
FD50mm f/3.5 Macro *****	Shooting Distance (in.) Magnification Field of View (in.)			8- $\frac{5}{16}$ 1.3 $\frac{11}{16} \times \frac{1}{16}$	8- $\frac{1}{2}$ 1.5 $\frac{5}{8} \times \frac{15}{16}$	8- $\frac{3}{4}$ 1.7 $\frac{9}{16} \times \frac{3}{16}$	9 1.9 $\frac{1}{2} \times \frac{3}{4}$	9- $\frac{5}{16}$ 2.1 $\frac{7}{16} \times \frac{11}{16}$	9- $\frac{5}{8}$ 2.3 $\frac{7}{16} \times \frac{5}{8}$	9- $\frac{15}{16}$ 2.5 $\frac{3}{8} \times \frac{9}{16}$	10- $\frac{1}{4}$ 2.7 $\frac{3}{8} \times \frac{1}{2}$	10- $\frac{5}{8}$ 2.9 $\frac{5}{16} \times \frac{1}{2}$	11 3.1 $\frac{5}{16} \times \frac{7}{16}$	11- $\frac{5}{16}$ 3.3 $\frac{5}{16} \times \frac{7}{16}$	11- $\frac{9}{16}$ 3.4 $\frac{1}{4} \times \frac{7}{16}$

* Effective when bellows extension is more than 19.5mm.

*** Effective when bellows extension is more than 14.5mm.

***** Effective when bellows extension is more than 30.5mm.

** Effective when bellows extension is more than 13.5mm.

**** Effective when bellows extension is more than 8.5mm.

Exposure Factor Conversion Table

Magnification	Exposure Factor	Exposure Correction Expressed in Exposure Degrees		Magnification	Exposure Factor	Exposure Correction Expressed in Exposure Degrees		Magnification	Exposure Factor	Exposure Correction Expressed in Exposure Degrees	
0.1	1.21	0.28	1/4	3.2	17.64	4.14	4 1/4	6.8	60.84	5.93	6
0.2	1.44	0.53	1/2	3.4	19.36	4.28	4 1/4	7.0	64.00	6.00	6
0.3	1.69	0.76	3/4	3.5	20.25	4.34	4 1/4	7.2	67.24	6.07	6
0.4	1.96	0.97	1	3.6	21.16	4.40	4 1/2	7.4	70.56	6.14	6 1/4
0.5	2.25	1.17	1 1/4	3.8	23.04	4.53	4 1/2	7.5	72.25	6.18	6 1/4
0.6	2.56	1.36	1 1/4	4.0	25.00	4.64	4 3/4	7.6	73.96	6.21	6 1/4
0.7	2.89	1.53	1 1/2	4.2	27.04	4.76	4 3/4	7.8	77.44	6.28	6 1/4
0.8	3.24	1.70	1 3/4	4.4	29.16	4.87	4 3/4	8.0	81.00	6.34	6 1/4
0.9	3.61	1.85	1 3/4	4.5	30.25	4.92	5	8.2	84.64	6.40	6 1/2
1.0	4.00	2.00	2	4.6	31.36	4.97	5	8.4	88.36	6.47	6 1/2
1.2	4.84	2.27	2 1/4	4.8	33.64	5.07	5	8.5	90.25	6.50	6 1/2
1.4	5.76	2.53	2 1/2	5.0	36.00	5.17	5 1/4	8.6	92.16	6.53	6 1/2
1.5	6.25	2.64	2 3/4	5.2	38.44	5.27	5 1/4	8.8	96.04	6.59	6 1/2
1.6	6.76	2.76	2 3/4	5.4	40.96	5.37	5 1/4	9.0	100.00	6.64	6 3/4
1.8	7.84	2.97	3	5.5	42.25	5.40	5 1/2	9.2	104.04	6.70	6 3/4
2.0	9.00	3.17	3 1/4	5.6	43.56	5.45	5 1/2	9.4	108.16	6.76	6 3/4
2.2	10.24	3.36	3 1/4	5.8	46.24	5.53	5 1/2	9.5	110.25	6.78	6 3/4
2.4	11.56	3.53	3 1/2	6.0	49.00	5.62	5 1/2	9.6	112.36	6.81	6 3/4
2.5	12.25	3.61	3 1/2	6.2	51.84	5.70	5 3/4	9.8	116.64	6.87	6 3/4
2.6	12.96	3.70	3 3/4	6.4	54.76	5.78	5 3/4	10.0	121.00	6.92	7
2.8	14.44	3.85	3 3/4	6.5	56.25	5.81	5 3/4				
3.0	16.00	4.00	4	6.6	57.76	5.85	5 3/4				

Flash Photography

For close-range work and photomacrography, the workable aperture becomes less than the marked aperture on the lens. The change in the effective aperture due to fall-off in light intensity as the lens is extended out is no longer negligible. The usual guide number and f/stop from automatic flash photography cannot be relied upon and true aperture must be found out to make the required exposure compensation. And in order to prevent irregular light distribution on the picture arising from the difference between the optical axes of the electronic flash unit and the lens, the electronic flash unit should usually be placed off-camera by using a cord.

Guide Number and Exposure Compensation

For close-range work guide number, use the following calculation on the condition the flash is used off-camera.

$$\text{aperture} = \frac{\text{guide number}}{\text{flash distance}}$$

When doing the math, make sure both guide number and the flash distance are in the same unit.

With the guide number of f/16 (meter), for example, for the flash unit and assuming the distance between the flash and the subject is one meter, f/16 is obtained from the equation $F = 16/1$. Next the exposure correction is to be made in the same way corrections are made over the metered exposure value in close-range work. If the camera is positioned to obtain 1.5x magnification, refer to the exposure factor conversion table on page 30 for the amount of exposure correction to be made. According to this table, the exposure must be increased by 2-3/4 exposure degrees for a magnification of 1-1/2x. For making the correction, the lens should be opened 2-3/4 f/stops from f/16. Since there is no one quarter click stop between the f/stops on the lens, set the aperture ring to f/5.6 which is slightly more than the required exposure increase but within the exposure tolerance. But in close-range magnification work, the depth of field becomes quite shallow and it is desirable to shorten the flash distance instead of opening the aperture. One of the solutions to this problem is to position the camera on the Bellows unit to a specific magnification from

where it is easy to make exposure compensation.

In photography using electronic flash unit, there can be many situations which affect exposures. It is best to obtain fine results through experience and test shots. After finding out the amount of exposure correction and opening the diaphragm to a certain f/stop, take extra shots of one f/stop over and under as well.

Procedures for Flash Photography

1. Position the camera on the Bellows scale in accordance with the magnification quired.
 2. Determine where the flash unit will be placed off-camera.
 3. Use guide number to determine the f/stop required for the flash to subject distance.
 4. Make exposure correction necessary for close-range work by opening the f/stops.
 5. Decide the picture composition and focus on the subject.
 6. Press the shutter button.
- * For more information, refer to books especially devoted on the subject.

Table of Accessory Length

Accessory		Length
Macro Auto Ring		10mm
Extension Tube FD 15-U		15mm
Extension Tube FD 25-U		25.8mm
Extension Tube FD 50-U		50mm
Extension Tube	FL15	15mm
	FL25	25mm
	M5	5mm
	M10	10mm
	M20	20mm
Macrophoto Coupler FL	52mm	20mm + 13mm
	55mm	20mm + 13mm
	58mm	20mm + 13mm
Macrophoto Adapter	MA52	5mm
	MA55	5mm
	MA58	5mm
Vari-Extension Tube	M15-25	15mm + 10mm
	M30-55	30mm + 25mm
Mount Converter A		2.8mm
Mount Converter B		13.2mm
Extension Tube	6mm	6mm
	9mm	9mm
	12mm	12mm
	25mm	25mm

Accessory		Length
Extension Tube	50mm	50mm
	75mm	75mm
	100mm	100mm
	150mm	150mm
	200mm	200mm

Extension Length of Lenses Attached in Reversed Direction Using Macrophoto Coupler FL

FD Lenses without a Locking Collar		FD Lenses with a Locking Collar	
FD 35mm f/2	44mm	FD 35mm f/2 S.S.C.	51mm
FD 35mm f/2.8	42mm	FD 35mm f/3.5 S.C.	47mm
FD 50mm f/1.2	40mm	FD 50mm f/1.8 S.C.	35mm
FD 50mm f/1.4	35mm	FD 50mm f/1.4 S.S.C.	47mm
FD 50mm f/1.8	25mm	FD 50mm f/3.5 S.S.C.	
FD 50mm f/3.5 Macro	39mm	Macro	41mm

- Total extension length when using Macrophoto Coupler FL is obtained by the following formula:
 Total extension length = Bellows scale length + Extension length of Macrophoto Coupler FL (20~33mm) + Extension length of each lens (given in the above table). Extension length in the above table is rounded to the nearest whole number.
- For the data when the front plate of the bellows is turned around, see the tables on pages 26 and 27. There is no need to go through the process of calculation.

Accessories for Close-ups and Photomacrography

Canon Macrophoto Couplers FL 52 and FL 58

The macrophoto coupler is attached between the lens and the camera body for mounting the lens in reverse to obtain higher magnifications with improved image quality. They are available in the two diameters of 52mm and 58mm corresponding to the lens filter size.

When an FD lens is reverse-mounted onto the Auto Bellows by means of the macrophoto coupler, automatic diaphragm coupling is possible by attaching the Macro Auto Ring and using the Canon Double Cable Release.

Canon Macrophoto Adapters MA-52 and MA-58

These accessories are for attaching the lens in reversed position to obtain higher magnifications in close-up photography. The adapters are available in the two diameters of 52mm and 58mm. Macrophoto Adapter may be interposed between the lens and a bellows unit, between the lens and extension tubes such as Extension Tubes M (of 5mm, 10mm, or 20mm length) or one of the Extension

Tubes FD-U. Focusing is possible with bellows movement.

Canon Extension Tubes FD 15-U, FD 25-U and FD 50-U

These tubes are 15, 25, and 50mm in length. Their special merit is that they are intermediate tubes with full FD functions. In other words, full aperture metering and automatic diaphragm coupling are possible. The Extension Tubes can be used with any Canon FD lens having a focal length from 35mm to 200mm except for the FD 85mm f/1.2 L. The FD 15-U can also be used with FD 28mm lenses. Only one Extension Tube FD-U should be used between the FD lens and the camera.

Canon Vari-Extension Tubes M15-25 and M30-55

The Vari-Extension Tubes M15-25 and M30-55 are used between the camera body and the lens. With extensions up to 10mm and 25mm for the M15-25 and M30-55 tubes respectively, a wide range of image magnifications is attainable. Manual diaphragm control is necessary unless the

Macro Auto Ring and Double Cable release are attached for automatic diaphragm control. When the lens is reversed, a Macrophoto Adapter MA and Macro Auto Ring (or Macro Hood) are used in combination.

Canon Duplicator 35

This is an accessory designed for use with the Auto Bellows which reproduces a 35mm slide, mounted or unmounted. Trimming is possible by reproducing only a part of the 35mm film frame. It will also duplicate 110 slides into 35mm slides. And to make duplication of slides in long strip form easier, the Canon Roll Film stage attaches to the front of the Duplicator 35.

Canon Roll Film Stage

This accessory is used with the Canon Duplicator 35 when duplicating from 35mm bulk film to make handling the bulk film easier.

* Please refer to the table on page 32 for the extension length for various attachments.

Canon Duplicator G

This is an accessory for duplicating and enlarging single frames of a gastro camera. The Duplicator G is used in combination with Macrophoto Lens 20mm f/3.5 and a bellows unit. In place of a bellows, other accessories such as Extension Tubes M and Macrophoto Couplers FL may be used. Focusing is possible with bellows movement.

Canon Duplicators 16 and 8

These accessories are used with the Canon macrophoto lenses and the Auto Bellows for duplicating a movie film frame into a 35mm film frame. Duplicator 16 duplicates 16mm movie film into 35mm film while Duplicator 8 reproduces 8mm movie film into 35mm film.

* Please refer to the table on page 32 for the extension length for various attachments.

Canon Macrophoto Lenses 20mm f/3.5 and 35mm f/2.8

Ordinary lenses are not designed for photomacrography calling for great magnifications. When they are used for high-magnification photomacrography, image quality tends to decrease with increased magnification. The Canon macrophoto lenses 20mm f/3.5 and 35mm f/2.8 are specially corrected to give optimum image quality in such high magnification photography. When used with the Auto Bellows, macrophoto lens 20mm f/3.5 gives 4 to 10X magnifications and the 35mm f/2.8, 2 to 5X magnifications.

Canon Macro Auto Ring

When the Macro Auto Ring is attached to the lens mount and used with the Canon Double Cable Release, automatic diaphragm coupling is possible even when non-automatic accessories, such as Extension Tubes M or a Vari-Extension Tube, are inserted between the lens and the camera body or when the lens is mounted in reverse, using Macrophoto Coupler FL.

Canon Macro Stage

This accessory, which has a built-in diffusion screen helps to hold the subject in place for close-ups and photomacrography. It is principally designed for use with the Canon macrophoto lenses when attached to the Auto Bellows, but it can also be used with a Canon 50mm standard lens.

Canon Copy Stand 5

This is a sophisticated copy stand for holding the camera steady during delicate photography such as copying and photomicrography. A weight balance built into its pole ensures smooth, light operation of the arm for changing the position of the camera to vary the shooting distance.

Canon Copy Stand 4

This is a high-quality copy stand with simpler design but made to the same exacting standard as the Copy Stand 5.

Canon Focusing Rail

This accessory can be attached to the arm of either Copy Stand 4 or Copy Stand 5 to facilitate fine adjustments in camera position.

Canon Macro Lenses FD 50mm f/3.5, FD 100mm f/4, and FD 200mm f/4

These lenses are high-quality lenses specially aberration-corrected to give excellent image quality at close shooting distances. Alone, the 50mm and 100mm Macro lenses are capable of magnification up to 0.5x and with one of the Extension Tubes FD, the magnification increases to life-size. With the 200mm Macro, new system is used, and the focusing range extends far enough for 1:1 life-size photography without the use of an accessory tube. All three Macro lenses can be used in general photography as well at shooting distances up to infinity and the lenses also feature full aperture metering and automatic diaphragm control coupling. The lenses are optically ideally suited for close-ups and photomacrography and give top performance in copying when used with a bellows.

Lens Mount Converter A

This accessory contains a female breech-lock ring and female screw thread for mounting Canon screw mount accessories onto Canon breech-lock mounts of single-lens reflex cameras and bellows. It is also used to connect the Microphoto Hood necessary in photomicrography using the bellows.

Lens Mount Converter B

This accessory contains a male breech-lock mount and male screw thread for mounting Canon lenses and accessories with a breech-lock mount onto Canon screw-mount accessories.

Extension Tubes (Screw-Mount) A (6mm), B (9mm), C (12mm), 25, 50, 75, 100, 150 and 200mm

These tubes of fixed lengths have a screw mount and are attached to a breech-lock mount bellows by using Lens Mount Converter B at the rear of the tube. When using a number of tubes, it is practicable to limit the extensions within 300mm.

Extension Tube M Set

This set includes one 5mm tube, one 10mm tube and two 20mm tubes. With the attachment to the standard lens, they are used for making possible reproduction ratios up to 1:1. Used in conjunction with the bellows unit and Macrophoto Coupler FL (the latter for reversing the lens), reproduction ratios may be increased. Manual diaphragm control is necessary whether the lens is normally or reverse-mounted unless the Macro Auto Ring and Double Cable Release are attached.

* Please refer to the table on page 32 for the extension length for various attachments.

Canon

CANON INC. 7-1, Nishi-Shinjuku 2-Chome, Shinjuku-ku, Tokyo 163, Japan
Mailing address: P.O. Box 5050, Dai-ichi Seimei Building, Tokyo 163, Japan

U.S.A. **CANON U.S.A., INC. HEADQUARTERS**
One Canon Plaza, Lake Success, N.Y. 11042, U.S.A.
CANON U.S.A., INC. MANHATTAN SERVICE CENTER
600 Third Avenue, New York, N.Y. 10016, U.S.A.
CANON U.S.A., INC. ATLANTA BRANCH
6380 Peachtree Industrial Blvd., Norcross, Georgia 30071, U.S.A.
CANON U.S.A., INC. CHICAGO BRANCH
140 Industrial Drive, Elmhurst, Illinois 60126, U.S.A.
CANON U.S.A., INC. LOS ANGELES BRANCH
123 Paularino Avenue East, Costa Mesa, California 92626, U.S.A.
CANON U.S.A., INC. LOS ANGELES SERVICE CENTER
3321 Wilshire Blvd., Los Angeles, California 90010, U.S.A.
CANON U.S.A., INC. SANTA CLARA BRANCH
4000 Burton Drive, Santa Clara, California 95054, U.S.A.
CANON U.S.A., INC. DALLAS OFFICE
3200, Regent Blvd., Irving, Texas 75063-3145, U.S.A.
CANON U.S.A., INC. HONOLULU OFFICE
Bldg. B-2, 1050 Ala Moana Blvd., Honolulu, Hawaii 96814, U.S.A.

CANADA **CANON CANADA INC. HEADQUARTERS**
6390 Dixie Road, Mississauga, Ontario L5T 1P7, Canada
CANON CANADA INC. MONTREAL SERVICE CENTRE
10652 Côte de Liesse, Lachine, Quebec H8T 1A5, Canada
CANON CANADA INC. CALGARY OFFICE
2828, 16th Street, N.E. Calgary, Alberta T2E 7K7, Canada

EUROPE, AFRICA & MIDDLE EAST **CANON EUROPA N.V.**
P.O. Box 7907, 1008 AC Amsterdam, The Netherlands
CANON FRANCE-PHOTO CINEMA S.A.
30, boulevard Vital-Bouhot, Ile de la Jatte, 92521 Neuilly-sur-Seine, France
CANON UK LTD.
Units 4 & 5, Brent Trading Centre, North Circular Road, London NW10 0JF, United Kingdom
CANON EURO-PHOTO G.m.b.H
Linsellesstraße 142-156, D-4156 Willich 3, West Germany

CENTRAL & SOUTH AMERICA **CANON LATIN AMERICA, INC. DEPTO. DE VENTAS**
Apartado 7022, Panamá 5, República de Panamá
CANON LATIN AMERICA, INC. CENTRO DE SERVICIO Y REPARACION
Apartado 2019, Zona Libre de Colón, República de Panamá

SOUTHEAST ASIA **CANON HONG KONG TRADING CO., LTD.**
Golden Bear Industrial Centre, 7/F., 66-82 Chai Wan Kok Street,
Tsuen Wan, New Territories, Hong Kong
CANON SINGAPORE PTE. LTD.
95 South Bridge Road #13-01/15, South Bridge Centre, Singapore 0105

OCEANIA **CANON AUSTRALIA PTY. LTD.**
Unit 1/37, Waterloo Road, North Ryde (Macquarie Park), N.S.W. 2113, Australia

JAPAN **CANON SALES CO., INC.**
11-28, Mita, 3-Chome, Minato-ku, Tokyo 108, Japan